



Combining advanced wood-burning technology and dramatic aesthetics, this highly efficient, EPA-certified fireplace delivers optimal heat and modern refinement in one outstanding showpiece.

LENNOX
HEARTH PRODUCTS

DAVE LENNOX
signature
COLLECTION

The Dave Lennox *Signature™* Collection Ladera™ high-efficiency wood-burning fireplace is a contemporary marvel. Advanced features, like a Double-Air Combustion control, allow you to enjoy a continuous fire without the need for reignites and help optimize efficiency. A compact, yet open, firebox accepts logs up to 18" for large flames, long burn times and additional warmth. And with a clean-face design and expansive viewing area, this EPA-certified fireplace allows you to take pleasure in the modern beauty of an unobstructed fire with a true masonry fireplace feel.



Ladera™ shown with black door



Brushed-nickel door

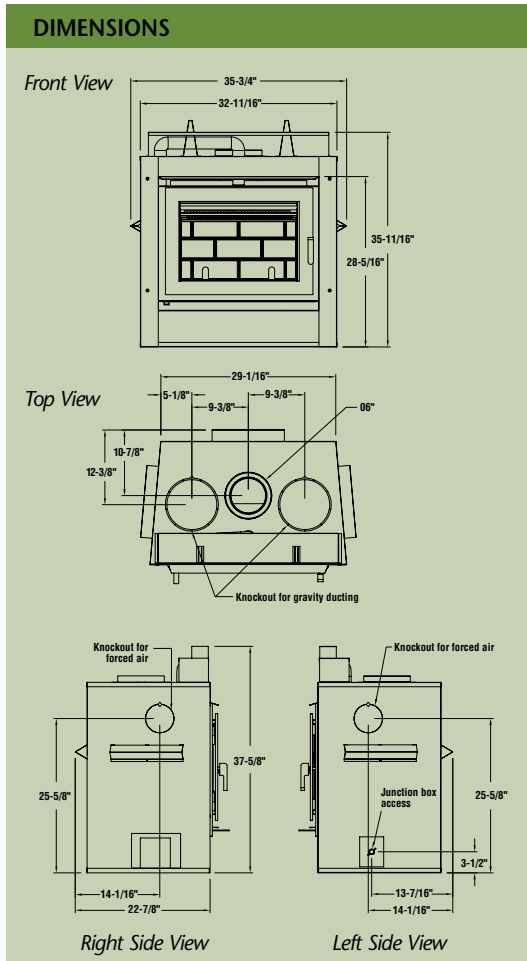

STANDARD FEATURES

EPA-certified

Heats up to 50,000 BTUs and up to 1,500 sq. ft.*

Louverless installation focuses on the beauty of the fire and mimics the look of a masonry fireplace

Zero clearance to combustibles

Airtight combustion chamber delivers maximum efficiency

Available with choice of black or brushed-nickel door

Convenient factory-installed fan for added value

All-in-one Double-Air Combustion control includes air boost for faster wood ignition and main air control for variable heat output

Efficient air wash system keeps glass clean

Firebox accepts up to 18" logs for greater heat output and longer burn times

Ceramic glass for added safety and optimum heat transfer

Expansive glass area allows for unobstructed views of the fire

Textured refractory-lined firebox recreates a traditional masonry appearance

20-year limited warranty

Backed by the Good Housekeeping Seal

*Square-foot heating capacities and burn times are approximations only. Actual performance may vary depending upon home design and insulation, ceiling heights, climate, condition and type of wood used, appliance location, burn rate, accessories chosen, chimney installation and how the appliance is operated.

**Use with Forced-Air Kit in the United States voids EPA certification.

OPTIONAL ACCESSORIES

Cast-iron surround and optional decorative keystone (35" H x 39-1/4" W)

Gravity air distribution kit

Forced-Air Kit**

Outside air kit

Rigid firescreen



Cast-iron surround



Cast-iron surround with decorative keystone

ENGINEERED TO BE THE BEST—COMMON FEATURES OF LENNOX EPA-CERTIFIED FIREPLACES

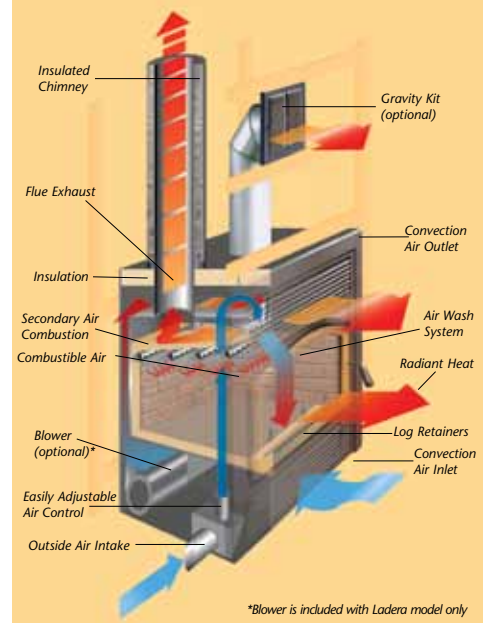

IMPORTANT NOTES:

As with any heating appliance, fireplace or stove, this appliance is extremely hot during operation. Read and understand all operating instructions before using this appliance. For further information, consult your dealer.

Diagrams, illustrations and photographs are not to scale—consult installation instructions. Product designs, materials, dimensions, specifications, colors and prices are subject to change or discontinuance without notice.

PRODUCTS AND DEALERS YOU CAN COUNT ON

Lennox is committed to providing you with the finest hearth products available. Choosing the right dealer for your hearth needs is as important as choosing the right brand, and our dealers are a big reason why you can count on quality customer service when you call.

HEARTH PRODUCTS

© Lennox Industries Inc. 2010

Visit us at www.lennox.com, or contact us at 1-800-9-LENNOX.

