

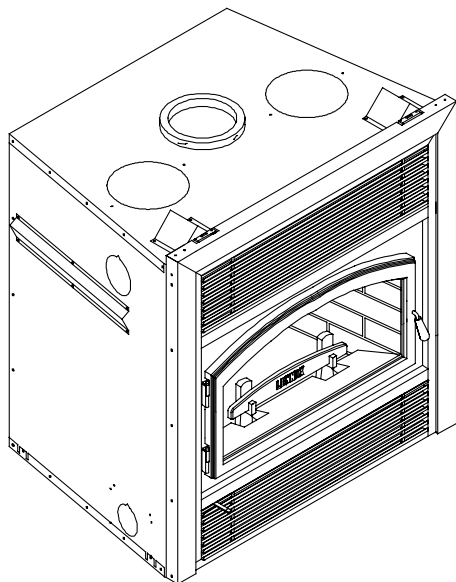

HEARTH PRODUCTS



SAVE THESE INSTRUCTIONS FOR FUTURE REFERENCE



WARNINGS

- Hot! Do not touch! The glass and surfaces of this appliance will be hot during operation and will retain heat for a while after shutting off the appliance. Severe burns may result.
- Carefully supervise children in the same room as appliance.



- If small children are present in the home, it is recommended that this appliance be fitted with a firescreen kit. See Page 20 for ordering information.



Listed to standards: ULC-S610 & UL-127 Report No. 3011202 EPA Cert. No. 537

INSTALLATION AND OPERATION INSTRUCTIONS

BRENTWOOD™

EPA Wood-Burning Fireplaces P/N 850,039M REV. H 05/2010



MODEL

BRENTWOOD SP

This installation manual will enable you to obtain a safe, efficient and dependable installation of your fireplace system. Please read and understand these instructions before beginning your installation.

Do not alter or modify the fireplace or its components under any circumstances. Any modification or alteration of the fireplace system, including but not limited to the fireplace, chimney components and accessories, may void the warranty, listings and approvals of this system and could result in an unsafe and potentially dangerous installation.

Lennox Hearth Products wood-burning fireplaces are designed for use as a supplemental heater. They are not intended for continuous use as a primary heat source.

Fireplace, also for use in mobile or manufactured homes with solid fuel only.

WARNINGS

- The fireplace cannot be operated without a door or firescreen. Consult your dealer to select the correct door or firescreen.
- Important! To assure proper alignment of glass doors: Install this fireplace in a square and plumb condition, using shims as necessary at sides and/or bottom.
- Install the fireplace only as described in these instructions.



www.nficertified.org

We recommend that our woodburning hearth products be installed and serviced by professionals who are certified in the U.S. by the National Fireplace Institute® (NFI) as NFI Woodburning Specialists or who are certified in Canada by Wood Energy Technical Training (WETT).



IMPORTANT! GENERAL SAFETY PRECAUTIONS. READ AND UNDERSTAND THESE SAFETY RULES BEFORE YOUR FIRST FIRE.

⚠ WARNING

THE FIREPLACE MUST BE OPERATED WITH THE DOOR FULLY OPENED OR DOOR FULLY CLOSED. IF THE DOORS ARE LEFT PARTLY OPENED, GAS AND FLAME MAY BE DRAWN OUT OF THE FIREPLACE OPENING, CREATING RISKS OF BOTH FIRE AND SMOKE. IF THE UNIT IS OPERATED WITH THE DOORS FULLY OPENED, THE OPTIONAL FIRE SCREEN MUST BE USED.

⚠ WARNING

NEVER use gasoline, gasoline-type lantern fuel, kerosene, charcoal lighter fluid, naphtha, engine oil or similar liquids to start or "freshen up" a fire in this fireplace. Keep any flammable liquids a safe distance from the fireplace at all times.

⚠ WARNING

THIS FIREPLACE HAS NOT BEEN TESTED WITH AN UNVENTED GAS LOGS OR A FIREPLACE INSERT. TO REDUCE RISK OF FIRE OR INJURY, DO NOT INSTALL AN UNVENTED GAS LOG SET OR FIREPLACE INSERT OR OTHER PRODUCTS NOT SPECIFIED FOR USE WITH THIS FIREPLACE.

⚠ WARNING

Never leave your fireplace unattended while it is burning.

⚠ WARNING

To avoid the risk of damaging fireplace materials and increasing the risk of fire, do not use the fireplace to cook or warm food.

⚠ WARNING

Use care when selecting window treatments for windows located near the fireplace. Avoid using combustible flowing window treatments such as curtains on nearby windows that are of sufficient length to be blown in front of an open flame when the window is opened. Keep any combustible furniture, materials or decorative pillows at least 48" (1219 mm) from the front fireplace opening.

⚠ WARNING

Never modify or alter your fireplace system in any way. To do so may create a potential fire hazard and void the limited warranty, listings and approvals of this system.

⚠ IMPORTANT

When burning wood, use SOLID NATURAL DRY WELL-SEASONED WOOD ONLY. Hardwoods are recommended (soft woods tend to burn very quickly).

- **DO NOT** burn treated wood, charcoal, coal, trash, cardboard, driftwood, woods dipped in tar, Christmas tree greens, pitch, pine tar, creosote, chemical chimney cleaners, flame colorants, polystyrene packaging, wood products with synthetic binders (i.e. plywood). Plywood, lumber and other misc. materials can produce abnormally high temperatures, sputtering and smoking fires and may contain hazardous chemicals to treat insects and fungus.
- Burning unapproved fuels can produce excessive temperatures, beyond the design capabilities of the fireplace and may produce excess sparks or may contain hazardous chemicals. Burning unapproved fuels can result in a chimney fire, a house fire, personal injury, death or loss of property.

⚠ WARNING

Never leave children unattended when there is a fire burning in the fireplace.

⚠ WARNING

Always ensure that the air inlet to the fireplace is free from debris and any other obstructions that can block the entrance of air.

⚠ IMPORTANT

WHEN INSTALLED IN A MOBILE OR MANUFACTURED HOME:

- Mobile or manufactured home installations must be installed in accordance with the requirements of the Department of Housing and Urban Development (HUD) "Mobile Home Construction and Safety standards" for US or Canada Mortgage and Housing Corporation (CMHC) for Canada.
- The fireplace must be fastened to the floor by unfolding and screwing the small tabs on both sides at the bottom of the fireplace.
- It is necessary to have access openings, for inspection purpose only, into built-in enclosures surrounding the fireplace installation. Such openings to require a household tool for access.
- The vapor barrier of the mobile home shall be as close as possible of the location where the chimney assembly penetrates the ceiling and roof structure with no interference to the required clearance to combustible material.
- When the mobile or manufactured home has a flat roof, the Attic Radiation Shield must be installed from below going through the roof (See *Figures 19b and 19d*).
- **Warning:** Do not install in a sleeping room

⚠ WARNING

Neither the manufacturer nor the seller warrants "smoke free" operation nor are we responsible for inadequate system draft caused by mechanical systems, general construction conditions, inadequate chimney heights, adverse wind conditions and/or unusual environmental factors or conditions beyond our control.

CONGRATULATIONS!

When you purchased your new wood fireplace, you joined the ranks of thousands of individuals whose answer to their home heating needs reflects their concern for aesthetics, efficiency and our environment. We extend our continued support to help you achieve the maximum benefit and enjoyment available from your new wood fireplace.

Thank you for selecting a Lennox Hearth Products wood fireplace as the answer to your home supplemental heating needs.

TABLE OF CONTENTS

Safety Rules and Specifications for Mobile or Manufactured Home Installation.....	Page 2
Introduction	Page 3
Parts Required	Page 3
Optional Equipment.....	Page 3
Operating The Fireplace	Page 3
Fuel	Page 3
Combustion Control	Page 4
Refueling For Best Performance	Page 4
Smoking – Causes And Troubleshooting	Page 4
Important Cautions	Page 5
Maintaining Your Brentwood Fireplace	Page 5
Chimney Maintenance.....	Page 5
Dealing With A Chimney Fire.....	Page 5
Finish Door Casing Care.....	Page 5
Disposing of Ashes	Page 5
Refractory Installation.....	Page 6
Door Installation	Page 6
Door Adjustment.....	Page 6
Glass Care - Replacement	Page 7
Glass Care - Cleaning	Page 7
Gasket Replacement	Page 7
Fireplace Installation	Page 7
Locating The Brentwood	Page 7
Framing, Facing And Mantel.....	Page 8
Hearth Extension Requirements	Page 8
Cold Climate Installations.....	Page 8
Fireplace and Framing Dimensions	Page 9
Nailing Flanges.....	Page 10
Facing / Mantel.....	Page 10
Hot Air Ducting Installation	Page 11
Gravity Kit	Page 11
Outside Air Kit	Page 12
Chimney System.....	Page 13
Chimney Installation Notes	Page 13
Chimney Installation Instructions.....	Page 14
Offset Chimney Installation	Page 15
Angled Wall Radiation Shield	Page 17
Chimney Support Installation.....	Page 18
Chimney Chase And Multiple Terminations.....	Page 18
Chimney Adaptor	Page 18
Masonry Application Instructions	Page 19
Installation Accessories	Page 20
Chimney Components Lists	Page 21
Replacement Parts	Page 23
Specifications.....	Page 23
Clearances	Page 23
Product Reference Information.....	Page 24

THE FIREPLACE INTRODUCTION

The Brentwood wood-burning fireplace is an energy efficient, heat circulating, closed combustion fireplace. You will receive a lifetime of comfort and enjoyment from your fireplace provided it is installed, maintained and operated properly.

- Please read these instructions and retain this manual for future reference.
- Before beginning the fireplace installation, consult the local authorities to obtain your building permit and check your local building codes. Install the fireplace only as described in these instructions and using only Lennox Hearth Products components.
- This fireplace has been tested for CAN/ULC S610-M87 and ANSI/UL 127 under report number 3011202. It has also been tested for EPA 40 C.F.R Part 60, section 60.532(b). Certificate number 537.
- The Brentwood fireplace is not intended for use with a gas log set. Do not use a fireplace insert or any other product with this fireplace unless it is specified by Lennox for use with this appliance. Failure to follow these instructions will void the certification and the warranty of the fireplace and may result in an unsafe installation.
- Lennox Hearth Products wood fireplaces are designed for use as a supplemental heater. They are not intended for continuous use as a primary heat source.

PARTS REQUIRED

Fireplace Model Brentwood SP

• **6" diameter chimney** - model ASHT, S-2100+, HT6000+, HT6103+ or AC manufactured by Security Chimneys International only, including:

- Chimney lengths
- Elbows (where necessary)
- Associated components as per these installation instructions

• Decorative Cast Iron Door - Required (Order Separately)

- Available in black, gold or brushed nickel (see **Page 20**)

• Outside air kit (Included w/Fireplace)

OPTIONAL EQUIPMENT

• Additional Equipment (optional)

- AC Chimney Adaptor (required if using AC Chimney)
- AC chimney outside air kit
- Gravity venting system
- Panel for clean face option (only with gravity venting system)

- Forced Air Kit ①
- Rigid firescreen
- Fireplace Blower Kit
- Blower Speed Control

① **Not tested under EPA certification. If installed, this appliance no longer qualifies for EPA certification.**

OPERATING THE FIREPLACE

Fuel

USE SOLID NATURAL WOOD FUEL ONLY. The Brentwood fireplace is designed to work best when fueled with dry seasoned natural wood only. Hardwoods are preferred to softwoods since the energy content of wood is relative to its density. Hardwoods will result in a longer burning fire and less frequent refueling. A moisture content of 15% to 20% (seasoned) is recommended. Wood that has been cut and split and let to dry under a cover for a period of one year will usually meet that criteria. The required drying time will vary depending on the climate. Wood that is packed tight together will take longer to dry. Seasoned wood is darker in color than wet wood and will have visible cracks in the grain on the ends. Excessively wet wood will be difficult to burn and will result in lower efficiency, increased creosoting and deposits on the glass and in the chimney. Excessively dry wood will burn well but will also have higher emissions and shorter burning time.

Do not burn scrap or garbage, treated wood or wood such as driftwood from the ocean which has been exposed to salt or other chemicals. Salt or chemicals can corrode the firebox and chimney. Do not burn large amounts of paper, cardboard, Christmas tree branches or building construction materials. Intense firing with these materials may overheat the fireplace, causing damage to the unit, a fire or even possibly igniting a chimney fire if the chimney is creosoted. Burning unapproved fuel, resulting in excessive pollutants being emitted, may be prohibited and subject to a fine or other penalty by the authority having jurisdiction in your area.

Processed firelogs can be used. Use only firelogs that have been evaluated for the application of fireplace and refer to firelog warnings and caution markings on packaging prior to use.

First Fires

Before using the fireplace make sure to remove the plastic wrapping and EPA label on plated door. Remove any glue residue left by the label using mild soap.

The first five or six fires should be small fires of short duration (about 30 to 60 minutes). This will help cure the refractory bricks. During the first few fires of this appliance there may be some odor and smoke due to the curing of the paint, dust accumulation and burning off of lubricants used in the manufacturing process. It may set off a smoke alarm located in the same room. For this reason the room should be well ventilated for the first few fires.

! WARNING

Be careful adding wood fuel to the fire or handling fireplace tools such as shovels, tongs or pokers.

! WARNING

The bottom refractory can be cracked by excessive abuse such as tossing heavy logs onto the grate or gouging with fireplace tools. Exercise caution when adding wood to your fireplace.

Building a Fire (starting and maintaining a fire)

To start a fire, place several crumpled up balls of newspaper in the firebox. Place small dry pieces of kindling on top of the paper, criss-crossing the kindling so that there are air spaces in between. Keep the fuel far back enough so that air can get underneath. Open the air controls fully and light the newspaper. Once the newspaper and the kindling is well ignited, close the door. Once the kindling fire is well established, cord wood can be added (see *Primary Air Combustion Control* section for proper operation of the air controls).

The unit will burn best with 2-3 pieces of cord wood spaced 1 to 2 inches apart and allowing air to get under the fuel. Criss-crossing or arranging the fuel so that air can get underneath, will help the fire to get started easily. The unit should be operated with the air control fully open long enough to get the cord wood well ignited.

COMBUSTION CONTROLS

Primary Air and Air Boost Controls

There is no flue damper in the Brentwood™ fireplace. As is common with air tight stoves, the combustion air control sets the flow of air entering the firebox. This allows for a more precise control of the fire. The combustion air control is located below the door on the left side. The main source of air (primary air) entering the firebox can be diminished by moving the air combustion control from left to right. The primary air is fully opened when the air control is completely moved to the left. The air control device can also be used to add an extra boost of air especially during fire start up and reloading of the unit. Pulling the air combustion control will induce an air boost at the base of the fire allowing an easier fire start up. When the fire is well established, the control can be pushed in to shut down the air boost allowing for a longer burn time. The combustion air control should be in the closed position (primary air and air boost) when the fireplace is not in use. This will minimize air leakage up the chimney. The

combustion air control should be opened before opening the door to minimize the possibility of back draft coming into the room.

Accelerated Combustion

The maximum heat output for the Brentwood™ fireplace is achieved by burning with the door closed and the combustion air opened and pulled out. By this method, the Brentwood fireplace can produce up to 55,000 BTU of heat per hour. However, it will be necessary to reload with wood every one or two hours. This is the least efficient method of burning the Brentwood fireplace.

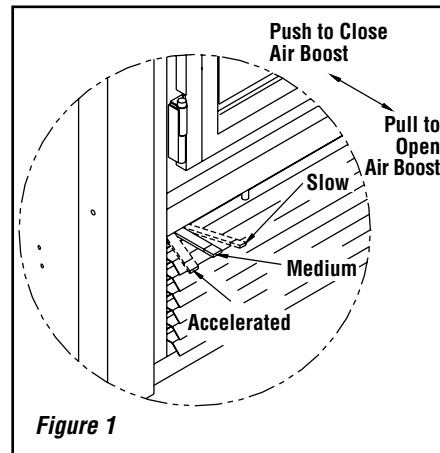

Figure 1

Use caution when firing with the combustion air control wide open. Only burn cord wood in this manner. Small dry pieces of softwood and construction scraps will burn very intensely using this method and may damage the firebox.

Medium Combustion

This is the recommended mode of operating the Brentwood fireplace and should be the one normally used since it will deposit the least amount of creosote on the glass and in the chimney. The combustion air control must be 3/4 closed and pushed in to close the air boost. The precise setting will depend on many factors, including chimney length and the moisture content of the wood.

For instance, a long chimney will necessitate closing the damper more. To obtain the proper combustion, close the damper completely, then open it about 1/4" to 1/2". Three medium size pieces of wood should be burning on a bed of hot coals. The heat output will be approximately 30,000 BTU per hour and the loading time will be about every 3-4 hours. Softwoods may be burned using this method but the time will be substantially reduced.

Slow Combustion

When the air combustion control is completely closed, the fireplace is in a slow combustion phase. If the hearth is hot enough, slow combustion will not extinguish the fire, but there will be a noticeable change in the flame pattern. The flames will be slow and may appear dirty if the

wood is too wet (moisture content of 20% and more). Do not allow the wood to burn without flame, since this will produce excessive creosote in the unit.

Creosote may accumulate on the glass door. This method of burning should be used only after operating the Brentwood fireplace with the air control opened to produce a hot fire for about an hour or at medium pace for at least three (3) hours. Slow combustion can be used at night in order to reduce the heat output and to prolong the burn. The loading time will be between 6-8 hours.

REFUELING FOR BEST PERFORMANCE

The Brentwood fireplace will operate best if attention is given to operating the unit with the damper fully opened after refueling in order to bring the firebox and the chimney system up to their optimum operating temperature. Combustion efficiency is relative to firebox temperature. A temperature of 500° C (932° F) and up, with a visible flame, in the upper part of the firebox indicates a maximum efficiency. To obtain this temperature, the fireplace must be operated with the primary air and air boost controls fully opened during 10 to 20 minutes after reloading, depending on the heat and on the moisture content of the wood.

Once you have reached the desired temperature, the air boost can be closed and the primary air set to a medium setting. You know you have reached the desired temperature when, closing the primary air control, you can see a flame at the top of the firebox. The benefit of this technique will be cleaner glass, less creosoting, greater efficiency and the most pleasing fire for your enjoyment. If your fireplace is equipped with a forced air system, make sure the central blower is turned off during reloading to avoid smoking problems.

SMOKING – CAUSES AND TROUBLESHOOTING

To reduce the likelihood of smoking when opening the door, set the combustion air controls to the left before opening the door. Your fireplace has been designed and tested to provide smoke free operation. Occasionally, there may be a small amount of smoking upon lighting the fire, until the chimney heats up but this should not continue. If the fireplace continues to smoke it is probably for one of the following reasons:

A. Negative pressure in the house

As the fire burns, air goes up the chimney. This air must be replaced through leakage into the house or through the outside air duct. When operating the Brentwood fireplace, open a nearby window temporarily to check if there is adequate replacement air supply.

B. Blowers operating (e.g.: range hood)

- These blowers draw air out of the house and may actually cause a negative pressure in the house. Turn off all blowers and open a nearby window to determine if this is the cause of the problem.

NOTE: DIAGRAMS & ILLUSTRATIONS ARE NOT TO SCALE.

- C. Wetwood-** Wet or tarred wood will smoulder and smoke instead of burn properly. Your dealer can help you determine if you have properly seasoned wood for burning.
- D. Dirty or blocked chimney-** Check to make sure the chimney is clear and clean. If dirty call a certified chimney sweep or use a properly sized chimney brush to clean.
- E. Chimney not long enough-** The minimum chimney height is twelve (12) feet (3.7 m) not including the fireplace height. The chimney must extend at least three (3) feet (915 mm) above its point of contact with the roof and at least two (2) feet (610 mm) higher than any roof or wall within ten (10) feet (3 m) of it. When installed with offsets, the minimum chimney height is fifteen (15) feet. Additional height will increase draft and will decrease the tendency to smoke.
- F. Poor chimney draft-** With no fire, there should be sufficient draft to exhaust cigarette smoke introduced under the baffle. Chimneys installed against an outside wall without protection may generate back draft problems which will cause start-up problems. To prevent this, open a nearby window, roll up a piece of paper and light it. Then, hold it in the upper part of the firebox to warm up the chimney. Wait until the draft is sufficient, then start the fire.
- G. Blower for forced air kit operating -** Make sure that the blower is at the "off" position when you open the fireplace door for reloading.

IMPORTANT CAUTIONS

- A. Do not block the hot air vents to the fireplace as this will cause the fireplace to overheat.**
- B. Never use gasoline, gasoline-type lantern fuel, kerosene, charcoal lighter fluid, or similar liquids to start or 'freshen up' a fire in this fireplace. Keep all such liquids well away from the fireplace while it is in use.**
- C. Do not burn coal. The sulphur in coal will corrode the firebox.**
- D. Do not burn driftwood which has been in the ocean or salt water. The salt will corrode the firebox and chimney.**
- E. Do not burn wood in the area in front of the grate.**
- F. Do not abuse the unit by burning paper, or cardboard or construction material such as pressed wood, plywood or lumber. Wood protectors, metallic paper, coal, plastic, waste, sulphur and/or oil will damage the fireplace.**
- G. Do not allow the wood to smoulder or burn without flame, since this will produce excessive creosote in the unit as well as increased particulate emissions.**

MAINTAINING YOUR FIREPLACE

Creosote - Formation and Need for Removal

When wood is burned slowly, it produces tar and other organic vapors, which combine with expelled moisture to form creosote. The creosote vapors condense in the relatively cool chimney flue of a slow-burning fire.

As a result, creosote residue accumulates on the flue lining. When ignited this creosote makes an extremely hot fire.

The chimney shall be inspected at least twice a year during the heating season to determine when a creosote buildup has occurred.

When creosote has accumulated it shall be removed to reduce the risk of a chimney fire.

When the creosote accumulation is large, a creosote fire in the chimney can damage the chimney and overheat the surrounding wood framing. Creosote formation in a chimney can be minimized by making sure there is always visible flame burning, avoid smouldering fires and by proper refuelling techniques.

Chimney Maintenance

Regular chimney inspection and maintenance combined with proper operation will prevent chimney fires. Keep your chimney clean. Do not allow more than 1/16" (1.6 mm) creosote build up in your chimney. The amount of creosote will depend on variables such as frequency of use and type of fire. We recommend that you:

- A. Initially inspect the chimney system weekly. From this, you will learn how often it will be necessary to clean your chimney.
- B. Have your chimney cleaned by a qualified chimney sweep. If you wish to clean it yourself, we recommend using a stiff plastic or non-metallic brush. If a metal brush is used, its size should be slightly smaller than the flue to avoid damaging the chimney. Do not use a brush that will scratch the stainless steel interior of the chimney.
- C. Do not expect chemical cleaners to keep your chimney clean. The rain cap can be removed for inspection and/or cleaning of the chimney.

Top Baffle Removal Prior to Cleaning The Chimney

Before starting to clean your chimney, we recommend that you remove the top baffle to avoid creosote dust collection at the top of the baffle. Follow these steps to set the top baffle out of the way:

- 1. Remove the side refractory holder. They are located at the top of the refractory.
- 2. Lift the front baffle.
- 3. Slide the back baffle under the front baffle. You now have access to the chimney.

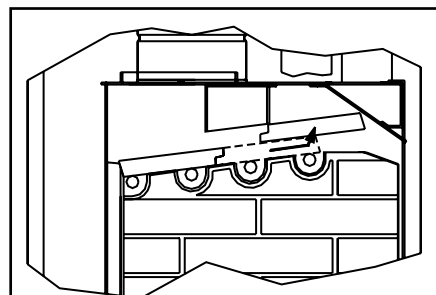

Figure 2a - Top Baffle Removal

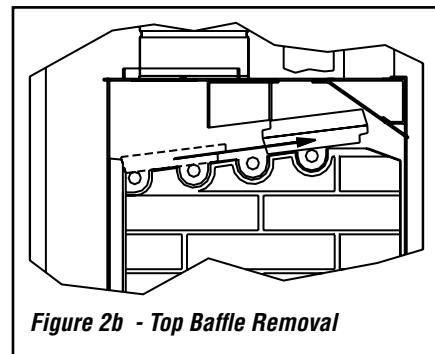

Figure 2b - Top Baffle Removal

Dealing With a Chimney Fire

Regular chimney maintenance and inspection can prevent chimney fires. If you have a chimney fire, follow these steps:

- 1. Close the fireplace door and the combustion air controls.
- 2. Alert your family of the possible danger.
- 3. If you require assistance, alert your fire department.
- 4. If possible, use a dry chemical fire extinguisher, baking soda or sand to control the fire. Do not use water as it may cause a dangerous steam explosion.
- 5. Check outside to ensure that sparks and hot embers coming out of the chimney are not igniting the roof.
- 6. Do not use the fireplace again until your chimney and fireplace have been inspected by a qualified chimney sweep or a Fire Department Inspector.

Finish Door Casing Care

Use a glass cleaner and a soft cloth to polish the casing. Do not use abrasives such as steel wool, steel pads or an abrasive polish for they may scratch the casing's finish.

DISPOSING OF ASHES

Note: For better performances, we recommend leaving 1/2 inch of ashes in the firebox.

Remove ashes only when the fire is out and the ashes are cold (24 to 48 hours after the fire is out). Do not leave the ashes in the house as they give off carbon monoxide and other toxic gases.

WARNING

Disposal of Ashes: Ashes should be placed in a metal container with a tight fitting lid. The closed container of ashes should be placed on a non-combustible floor or on the ground well away from all combustible materials, pending final disposal. If the ashes are disposed of by burial in soil or otherwise locally dispersed, they should be retained in the closed container until all cinders have thoroughly cooled.

REFRACTORY REPLACEMENT

The intense heat of the fire will normally cause hairline cracks in the refractory. These cracks can be minimized by proper curing as described in "First Fires". They will not normally diminish the effectiveness of the refractory. If large cracks develop, then the refractory should be replaced. To replace the refractory bricks, follow these steps:

1. Remove the front refractories
2. Remove the bottom refractory
3. Remove the left side refractory
4. Remove the right side refractory
5. Remove the back refractory
6. Remove the front ceramic baffle
7. Remove the rear ceramic baffle

To install the new refractories, follow the above steps in reverse.

DOOR INSTALLATION

The door must be installed only when the installation of the Brentwood™ fireplace is completed. All you have to do is fit the male part of the hinge, already on the door, to the female part, which is on the fireplace.

To remove the door, simply pull the door up from the hinges.

The door adjustment has been set at the factory. If the fit is still not perfect, you can adjust the door using the hinge screws.

DOOR ADJUSTMENT

The door may need to be adjusted to be completely airtight. The gaskets' air-tightness can be adjusted using the adjustment screw located on the right side of the fireplace facade (An Allen key #1/8 – not supplied - will be necessary for this adjustment).

Checking Door Seal - A one-inch strip of paper may be used to perform a test of the integrity of the door seal. Close the door on the paper in at least eight points. It is normal to feel only a slight amount of friction. The door gasket does not need to be "tight" in all areas, since a small amount of leakage is not hazardous or detrimental to the performance of your fireplace.

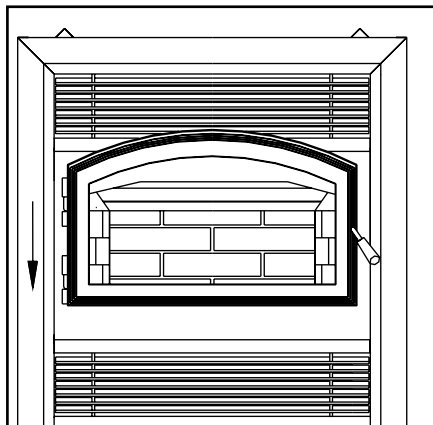

Figure 4 - Door Installation

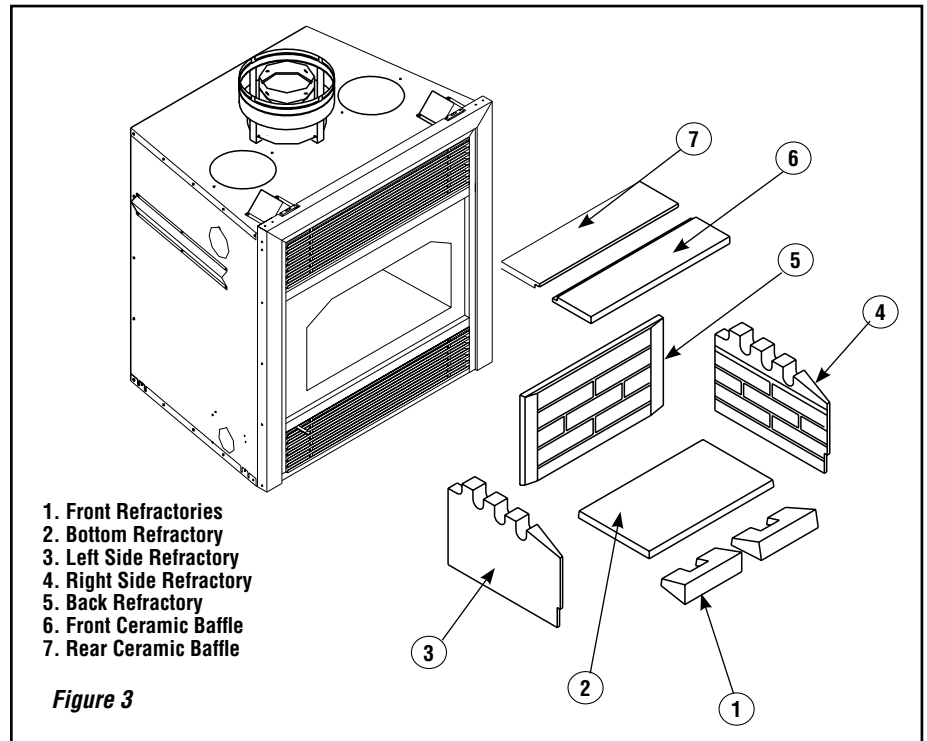

Figure 3

⚠ WARNINGS

- Use only a Lennox Hearth Products glass doors, specifically designed for the Brentwood fireplace.
- The fireplace cannot be operated without door or firescreen. Consult your dealer to select the correct replacement door or firescreen.
- Important! To assure proper alignment of glass doors: Install this fireplace in a square and plumb condition, using shims as necessary at sides and/or bottom.

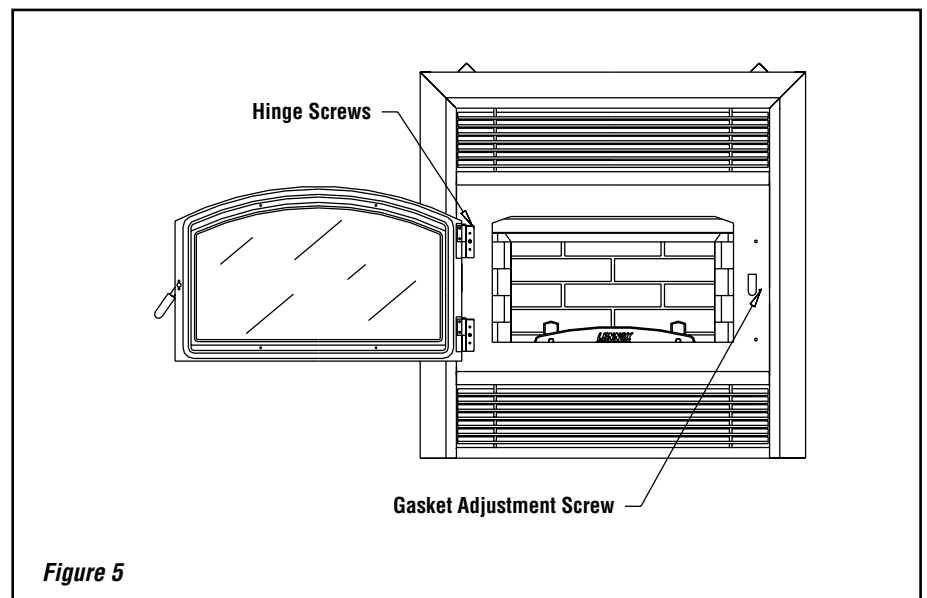

Figure 5

NOTE: DIAGRAMS & ILLUSTRATIONS ARE NOT TO SCALE.

GLASS CARE

Glass Replacement

The glass used for the Brentwood™ fireplace is a high temperature ceramic glass (1,400° F). If the glass breaks, it must be replaced with an identical ceramic glass. Tempered glass or ordinary glass will not withstand the high temperatures of the Brentwood fireplace. Replacement glass should be purchased from a Lennox Hearth Products dealer (see “Replacement Parts”, **Page 23**). **DO NOT OPERATE THE UNIT WITH CRACKED OR BROKEN GLASS.**

Glass Cleaning

The Brentwood fireplace is designed to keep the glass clean under normal operating conditions. If the Brentwood fireplace is operated continuously with the combustion air controls closed, the glass will tend to get dirty unless the fuel, firebox and glass are maintained at hot temperatures (see “Refueling For Best Performance”). To clean the glass, there are a number of specially designed cleaners. Your authorized Lennox Hearth Products dealer can recommend a suitable cleaner which is available in your area. Regular household glass cleaners will not clean creosote. Do not use abrasives such as steel pads, steel wool or oven cleaner as they will scratch the glass.

DO NOT USE CHEMICAL GLASS CLEANERS ON PAINTED SURFACES AS IT MAY CAUSE THE PAINT TO PEEL.

CAUTION: DO NOT ALLOW WINDOW CLEANER TO GET IN CONTACT WITH DOOR OR PAINT ON FACADE OR DOOR. ONCE CLOSED, CONTACT OF GLASS CLEANER WITH THE FIREPLACE FACADE CAN PROVOKE PAINT PEELING OFF.

Gasket Replacement

Remove the door from the unit (see **Page 6**) and lay it on a clean unabrasive surface. To replace the gasket, first remove all of the old gasket and gasket cement. Make sure that the surface is totally clean before applying new cement (a high temperature silicone caulking rated at 500° F [260° C] is suitable) or adhesion problems may result. Apply gasket cement to the gasket channel and install the new gasket. This replacement part is available from your Lennox Hearth Products dealer in the following dimensions:

Gasket	Length	Dimensions	Part No.
Around Glass	69 (1753)	5/16" dia. (8)	SR1823H
On Door Frame	73 (1854)	5/8 dia. (15.9)	SR1823G

Table 1 Inches (millimeters)

FIREPLACE INSTALLATION

Locating The Brentwood Fireplace

A. The best location to install your fireplace is determined by considering the location of windows, doors, and the traffic flow in the room where the fireplace is located, allowing space in front of the unit for the hearth extension and the mantel, and taking into consideration the location of the hot air ducts (optional), outside air kit and chimney.

If possible, you should choose a location where the chimney will pass through the house without cutting floor or roof joists (see fireplace dimensions **Page 9**).

- B. Usually, no additional floor support is needed for the fireplace. The adequacy of the floor can be checked by first estimating the weight of the fireplace system. Weights are given in the appendix. Note the floor construction and consult your local building code to determine if additional support is needed.
- C. The Brentwood fireplace may be installed directly on the floor or on a raised base (for proper guidelines, refer to “Hearth Extension Requirements”) and a minimum of 6’8” (2 m) measured from the base of the appliance to the ceiling is required.

When selecting the location, the chimney outlet position and the direction of the wind are important factors affecting the chimney performance. To allow a maximum draft and to reduce wind turbulence, the chimney must:

- Penetrate the highest part of the roof.
- Be installed as far as possible of roof offsets, trees or any other obstructions that may cause wind turbulence and back drafts in the chimney.
- The least amount of offsets (elbows) possible.

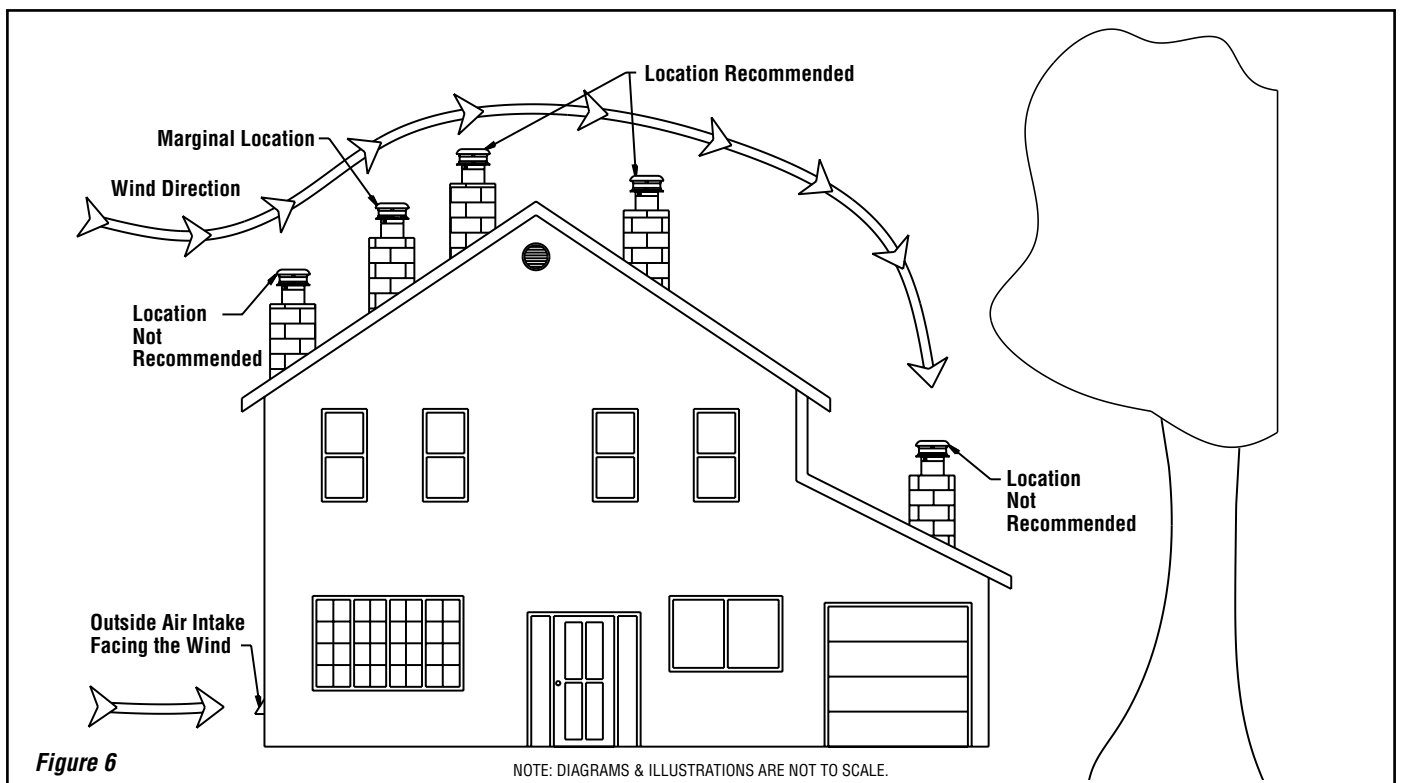

Framing, Facing And Mantel

The construction of the framing, facing, and mantel must be in accordance with the standards and the following illustrations (*Figures 7a, 7b and 8*):

- A. Frame the fireplace using 2" x 3" or heavier lumber.
- B. **WARNING: Combustible materials cannot be used in the space directly above the fireplace, except for the studs above the facade that support the facing and mantel. This area must remain empty for a height of 6'8" (2,032 mm) measured from the base of the appliance.**
- C. Frame the fireplace with vertical studs at the sides of the fireplace running from floor to ceiling (see *Figure 8*). If combustible facing is to be used, position the studs back, from the front edge of the fireplace (a space that is the thickness of the facing material, so that the facing can be installed flush with the fireplace facing). Frame headers between the vertical studs only as follows:
 - Place 2" x 3" or 2" x 4" headers, only along the upper part of the front, side and back faces (some codes may require a 2" x 6" on an outside bearing wall). Do not put wood or any combustible material within the area above the fireplace except on the front facing.
 - Place headers only as required to support the facing and mantel.
- D. **WARNING: The fireplace must not be in contact with any insulation or loose filling material. Cover the insulation with Drywall panels around the fireplace.**

Hearth Extension Requirements

The Brentwood fireplace may be installed directly on a combustible floor. The supplied safety metal strip must be positioned as follows: One half under the front of the fireplace and the other half must extend on the floor over which the hearth extension will be built (see *Figure 7a*).

* The safety metal strip must cover the entire width of the fireplace

The combustible floor in front of the fireplace must be covered with a non-combustible material (tile, marble, stone, etc). See *Figures 7a and 7b*.

COLD CLIMATE INSTALLATIONS

Climates where temperatures will fall below 32° F (0° C).

The heating performance of the appliance will vary depending upon the level of insulation, house design, how the appliance is operated, etc.

If this fireplace is being installed in a cold climate, it is especially important to seal all cracks around the fireplace and wherever cold air could enter the room with noncombustible material.

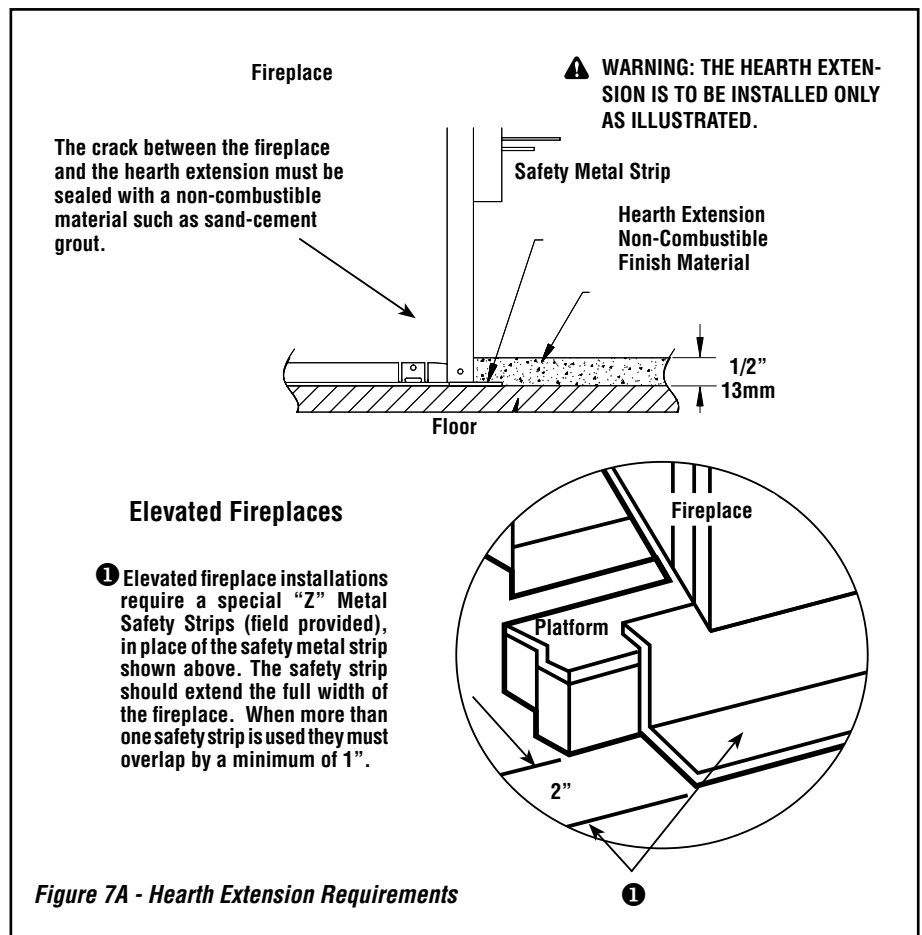

Figure 7A - Hearth Extension Requirements

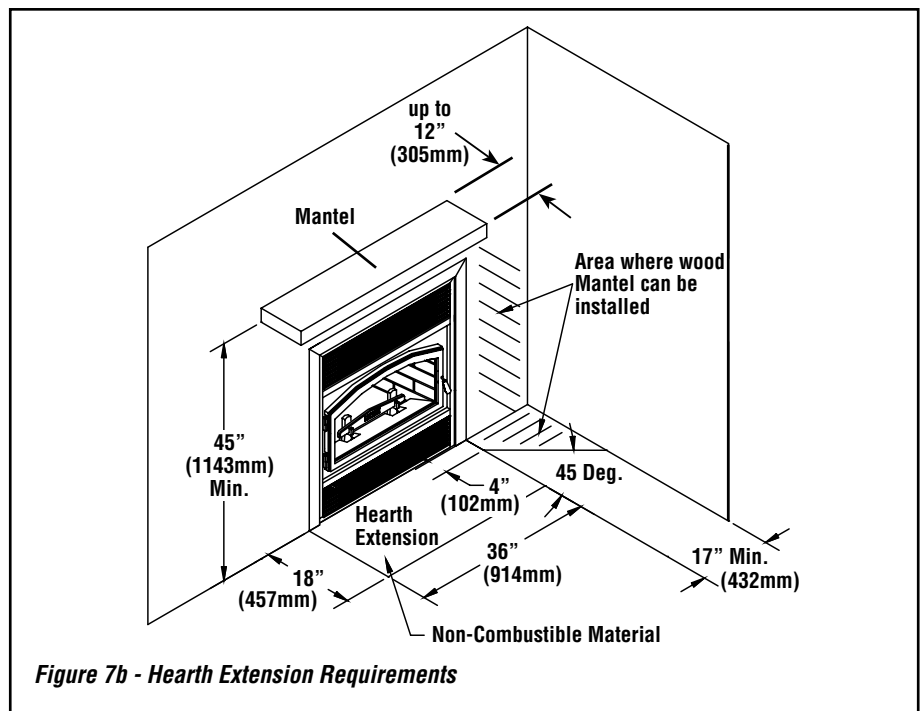
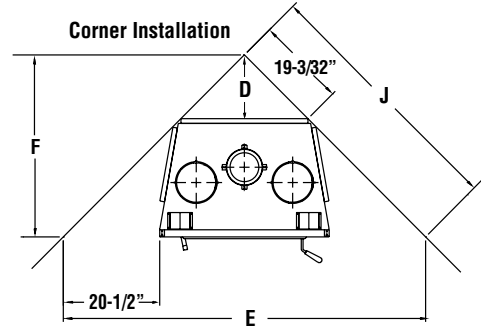
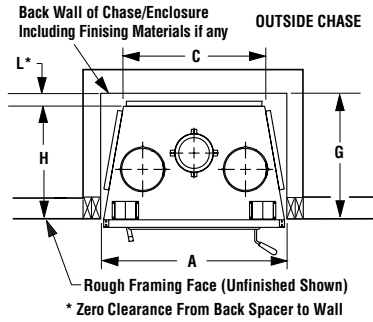
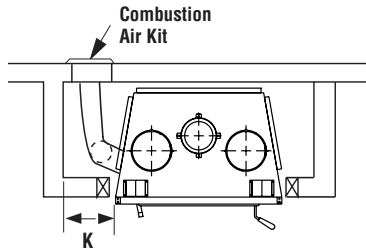

Figure 7b - Hearth Extension Requirements

Also, the outside air inlet duct should be wrapped with noncombustible insulation to minimize the formation of condensation. Do not place insulation materials directly against the chimney sections. We recommend that you use the insulated wall radiation shield since it will maintain the home's thermal barrier. AC chimney is NOT recommended in very cold climates (in areas with temperatures below 0°F (-18°C).

NOTE: DIAGRAMS & ILLUSTRATIONS ARE NOT TO SCALE.



FRAMING DIMENSIONS Fireplace Opening Width		
A	36-3/8"	924 mm
B	37"	940 mm
C	28-3/32"	714 mm
D	13-1/2"	343 mm
E	77"	1956 mm
F	38-1/2"	978 mm
G	*24-1/2"	603 mm
H	23-1/2"	597 mm
J	54-7/16"	1383 mm
K	8"	203 mm
L	1"	25 mm

Combustible materials can NOT be used in the space directly above the fireplace. Do not fill the space above the fireplace with any material (Except the wood framing)

* Total depth is 25 inches including the back spacer minus 1/2 inch for drywall to be flush with the facing.

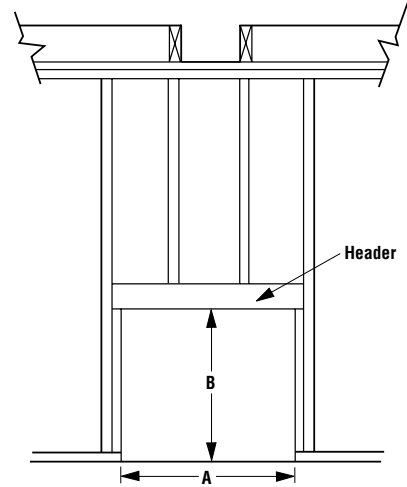
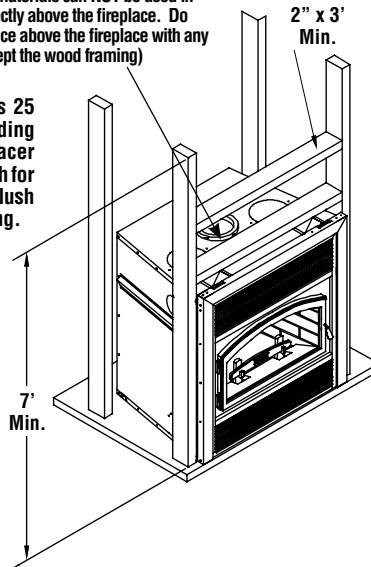

Combustible materials can NOT be used in the space directly above the fireplace. Do not fill the space above the fireplace with any material (Except the wood framing)

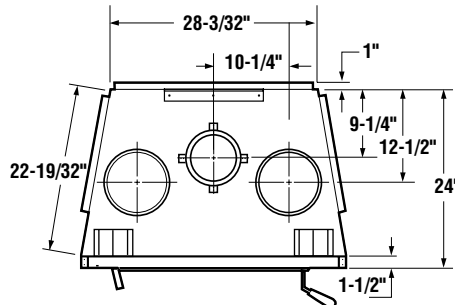
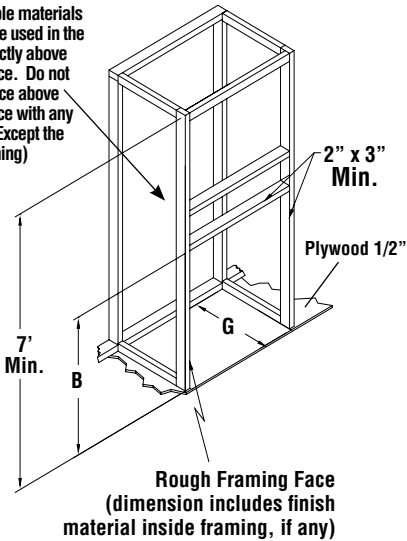

Notes
 Diagrams, illustrations and photographs are not to scale – consult installation instructions. Product designs, materials, dimensions, specifications, colors and prices are subject to change or discontinuance without notice.
 All framing dimensions calculated for 1/2" dry wall at the fireplace face. If sheathing the chase or finishing with other thickness materials, calculations will need to be made.
 * The fireplace must not be in contact with any insulation or loose filling material. Cover the insulation with Drywall panels around the fireplace.

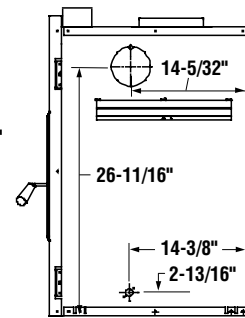
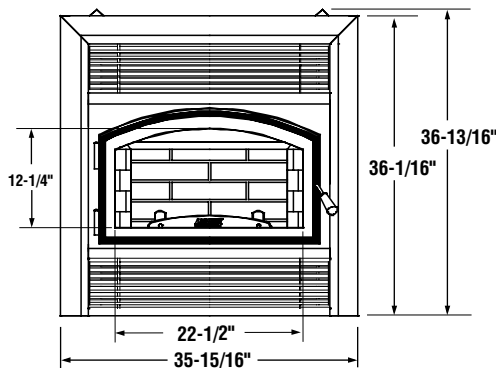
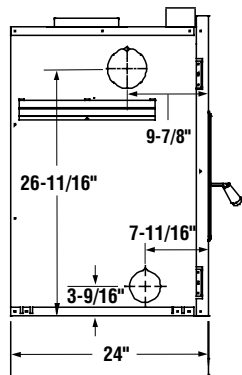
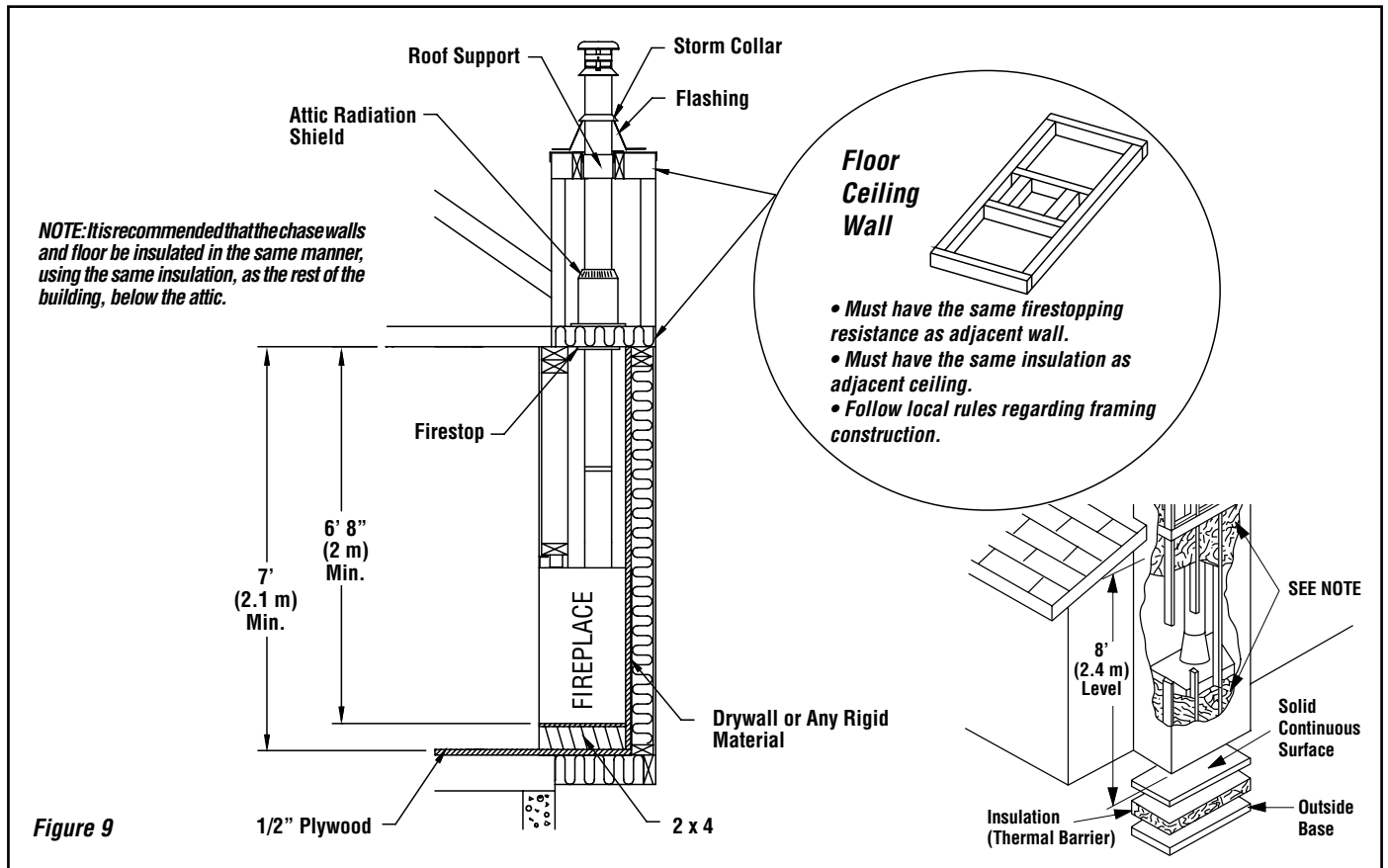

Figure 8 - Fireplace and Framing Dimensions

NOTE: DIAGRAMS & ILLUSTRATIONS ARE NOT TO SCALE.

Insulated Chase Construction



Nailing Flanges

Four nailing flanges are provided to secure the fireplace to the floor (see figure below). Bend the nailing flanges down so that each flange is flush with the floor, then using nails or screws, secure the fireplace to the floor (2 places each side). The heads of the screws or nails must be large enough to completely cover the holes in the nailing flanges.

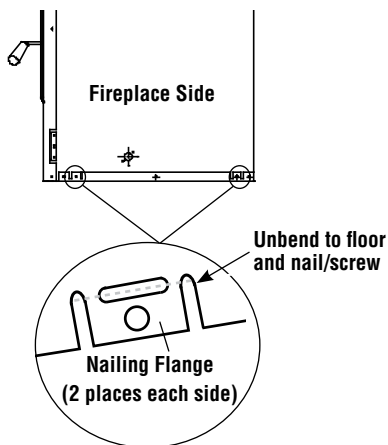

Facing

1. Combustible material must be installed flush with the fireplace. It may not project in front of and on the fireplace (i.e. the steel facade of the fireplace) (**Figure 10**).

2. Non-combustible materials such as brick, stone or ceramic tile may project in front of and onto the fireplace facing (**Figure 11**).

Mantel

The mantel must be installed at least 45" (1143 mm) above the base of the fireplace (**Figure 10**).

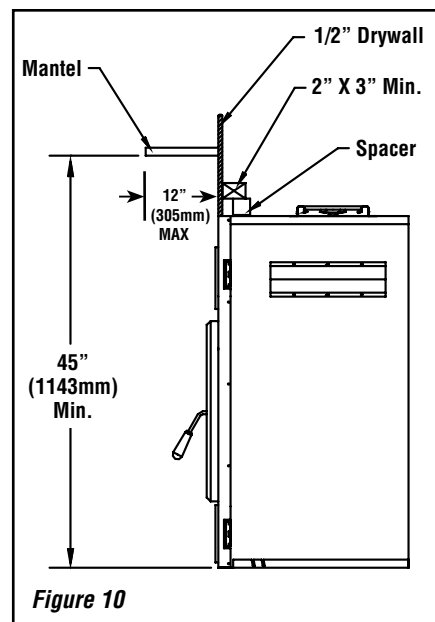

NOTE: DIAGRAMS & ILLUSTRATIONS ARE NOT TO SCALE.

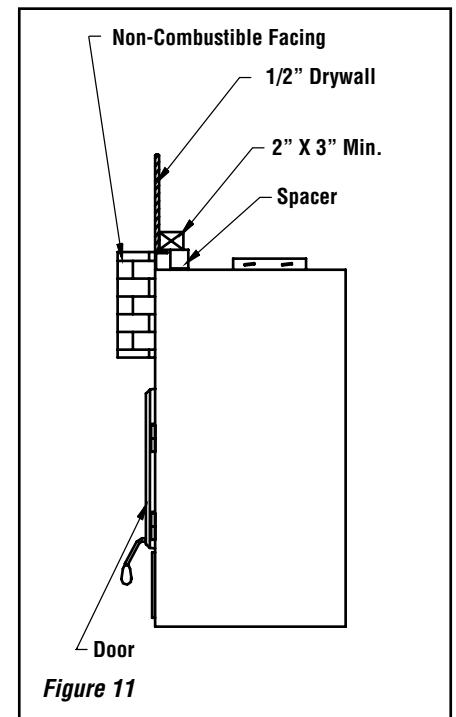

HOT AIR DUCTING INSTALLATION

The Brentwood™ fireplace is approved for use with a Gravity Kit.

Gravity Kit

The gravity kit is designed for double hot air outlets and includes: (See **Figures 12 and 13**)

- 2 telescopic lengths 8" I.D.
- 2 90° elbows 8" I.D.
- 2 hot air outlet kits (grill and frames)
- 2 adaptors

See *Gravity Kit Accessories* on **Page 20**.

The only blower that can be used with the gravity kit is the UZY5.

The gravity kit allows you to block the upper louver of the fireplace. To do so, follow the steps below:

- a) Remove the upper louver from the fireplace.
- b) Install the black panel (BWCF) making sure that the insulation strip is installed inside.
- c) The fireplace facade can be covered with non-combustible material (**Figure 14**).

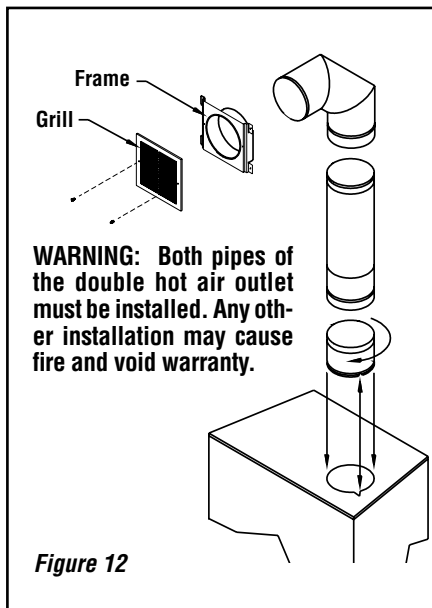

For safe installation, the gravity kit must meet the following requirements:

Minimum height* 68" (1,727 mm)
Maximum length See **Figures 13 and 14**

* The height of the louver must be measured from the base of the Brentwood fireplace to the middle point of the louver.

To extend the double outlet system forward of the Brentwood fireplace (not flush), it will be necessary to purchase two adjustable lengths (7B26ZL2A).

When installing the double outlet system, the hot air outlets can be installed in the same room as the fireplace, or one or both of the outlets can be installed in adjacent or upper rooms. Installing the ducts at different elevations will tend to exhaust more heat out of the higher outlet (**Figure 13**).

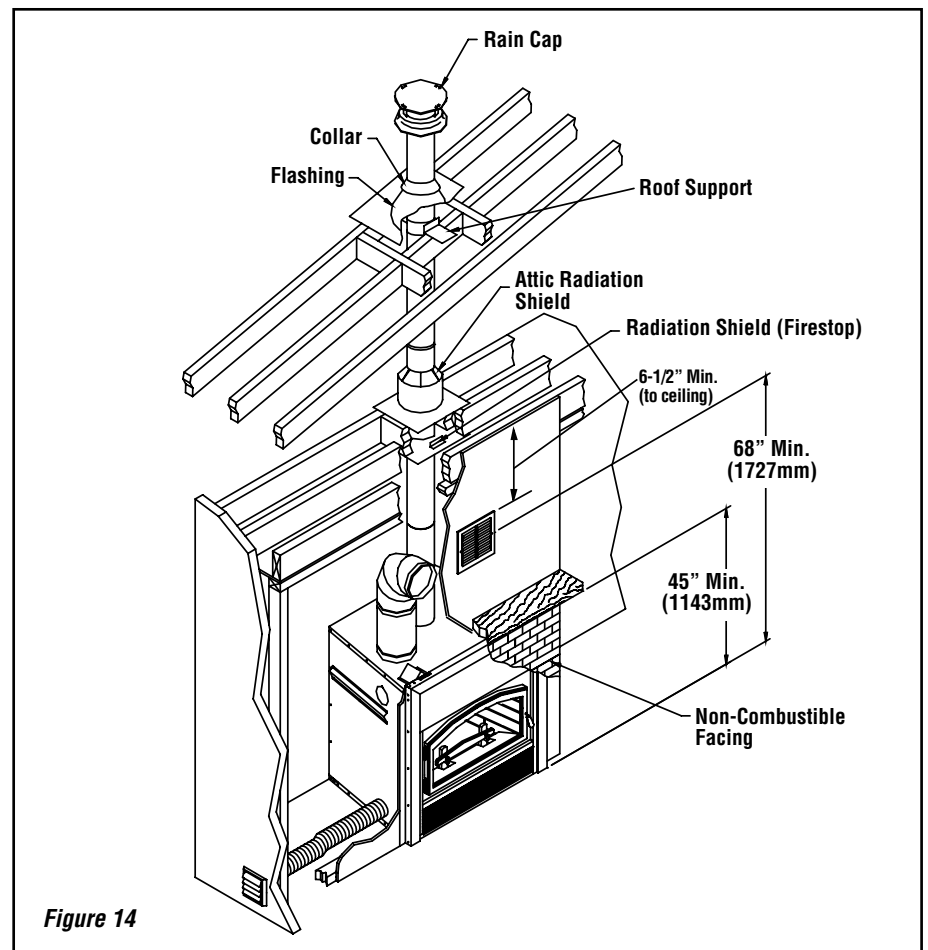
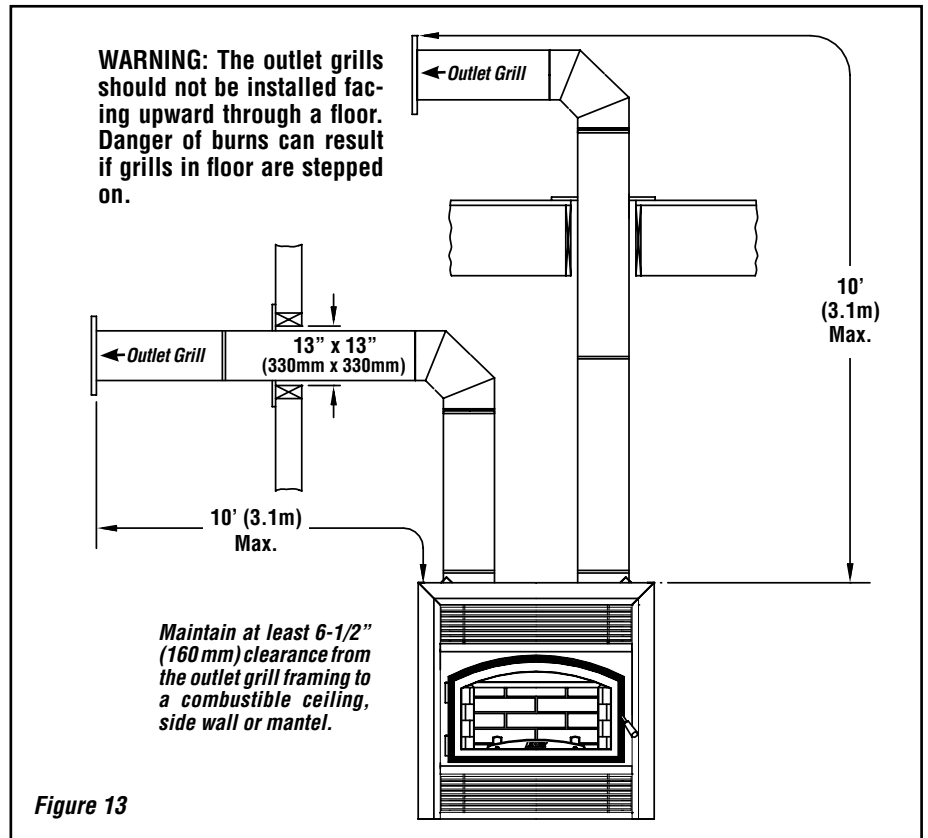

NOTE: DIAGRAMS & ILLUSTRATIONS ARE NOT TO SCALE.

The duct system must be installed respecting the following:

1. Remove the plates closing up the 8" dia. holes on top of the fireplace. Then, cut the insulation in order to obtain two 8" dia. openings. Fix the adaptors on the fireplace openings by turning clockwise (**Figure 12**).
2. Maintain at least a 2" (50 mm) clearance between the ducts and any combustible material; the required hole size is 13" x 13" (330 mm x 330 mm).

Exception #1: For the grills, the framing can be 10-3/4" x 10-3/4" (275 mm x 275 mm) to provide the clearance as required by the integral spacers on the double outlet duct system.

3. The maximum number of elbows in a run of duct is two.
4. Maintain at least 6-1/2" (160 mm) clearance from the outlet grill framing to a combustible ceiling, side wall or mantel.
5. When traversing a combustible wall or floor, a firestop must be installed at the wall or floor penetration. The hole size must be 13" X 13" (330 mm x 330 mm).
6. Do not connect the hot air ducts to a central heating system. Malfunction of the heating system's blower will cause the fireplace to overheat. A furnace duct is only single wall and not double wall as is required for the Brentwood™ fireplace hot air exhaust.
7. Use only Lennox Hearth Products grills and components as described in this manual. Other grills or registers, for example, may be too restrictive and may overheat the fireplace or ceiling.
8. Do not use insulated flexible ducts as they will overheat.
9. Do not use tees or any other components than the ones specifically listed here.
10. Never allow the ducting to pitch down as hot air will be trapped creating a fire hazard. **Never route the ducting downwards.**
11. The hot air outlet grills must be installed with the louvers pointing downwards in order to prevent overheating adjacent ceilings.
12. Always install the two outlet grills when using the double hot air outlet kit and blocking the upper louver of the fireplace.

OUTSIDE AIR KIT

During operation, the fireplace requires fresh air for combustion and draws air out of the house. It may starve other fuel burning appliances such as gas or oil furnaces. As well, exhaust blowers may compete for air, causing negative pressure in the house, resulting in smoke entering the house from the fireplace. This situation is aggravated in modern airtight houses. To overcome this problem, we strongly recommend that you install an outside air assembly. Check with local authorities having jurisdiction in your area, it may be mandatory.

Note: Should you decide not to install the outside air assembly, proceed as follows:

- Remove the bottom grill. The air box is located on front left and is on a slant.
- Unscrew the four screws holding the inside air box covering plate and remove it.

Outside Air Installation

The outside air assembly may be installed according to the following requirements:

- A) Duct length should be kept to a minimum. The maximum length of duct is twenty (20) feet (6.1 m) for a 4 in. dia. pipe (See note below).
- B) The air intake register must not be installed more than ten (10) feet (3050 mm) above the base of the fireplace.
- C) The fresh air must come from outside the house. The air intake must not draw air from the attic, from the basement or garage.
- D) The air intake should be installed where it is not likely to be blocked by snow or exposed to extreme wind and away from automobile exhaust fumes, gas meters and other vents.
- E) The duct and register may be installed above or below floor level.

The following components are required:

- Outside air kit (UZI) (includes 40 inch flex that goes up to ten (10) feet long)
- 4" Adaptor for fireplace connection (supplied with the unit)

Make a 4-1/4" (110 mm) hole in the outside wall of the house at the chosen location. From outside, place the outside air register in the hole (open side down) and fasten the register to the wall, with screws as shown (see **Figure 15**). Slip the pipe into the insulated sleeve. Place the insulated pipe over the register tube and over the fireplace's outside air connector (see **Figure 16**). At each end, carefully pull back the insulation and plastic cover exposing the flexible pipe. Using the aluminium tape provided, wrap the tape around the joint between the flexible pipe and the air inlets. Carefully push the insulation and plastic cover back over the pipe. Using aluminium tape, fasten the plastic cover in place.

Note: We recommend not to exceed 20 feet of 4" flexible pipe. If you require a longer length we recommend that you use a 5" diameter flexible pipe for the complete run up to 30 feet and a 6" diameter pipe for a run of up to 40 feet.

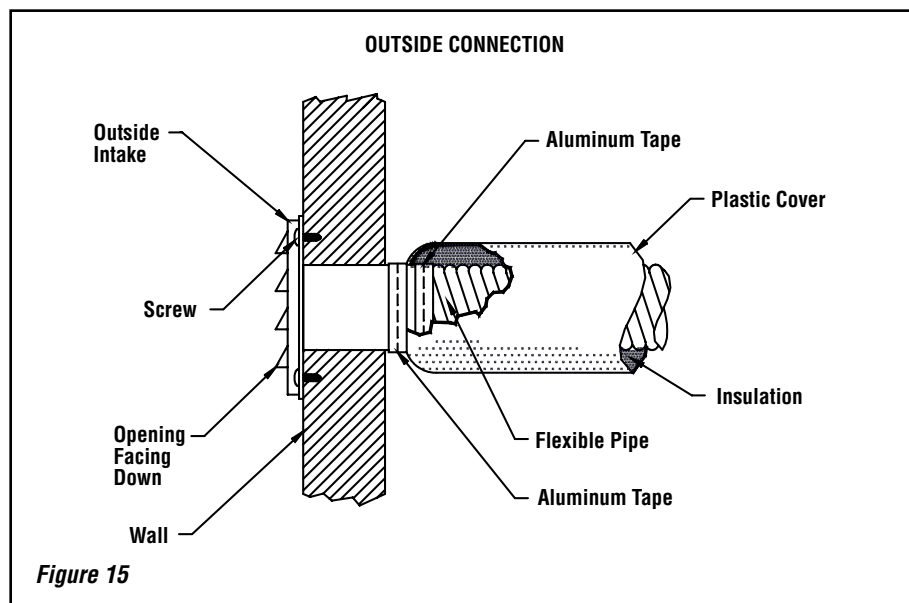

NOTE: DIAGRAMS & ILLUSTRATIONS ARE NOT TO SCALE.

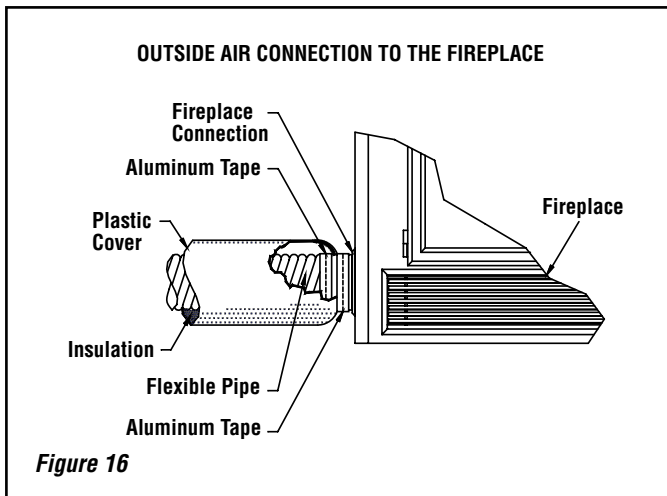

THE CHIMNEY SYSTEM

Chimney Installation Notes

1. Always install an interior chimney as it will provide better performance. In areas with continuous temperatures below - 18° C (0° F), the use of an exterior chimney increases the likelihood of operating problems such as low draft, high rate of creosoting, and poor start-up characteristics. Exterior chimneys are also prone to down drafting and flow reversal. Installations, which are located on lower floors in the house, such as in a basement, in combination with outside chimney, are especially prone to flow reversal. If interior installation is impossible, install an AC chimney enclosed in an insulated chase.
2. The fireplace model Brentwood SP may be installed only with Security Chimneys International Ltd 6" diameter chimney systems.
3. A chimney venting a fireplace shall not vent any other appliance.
4. The minimum chimney height is 12 feet (3.7 m). In altitude, add 18" (450 mm) to the chimney for every 2,000 feet (600 m) above sea level.
5. **All chimney installations must include at least one support.** The maximum length of chimney that can be supported by the fireplace is 26 feet (8 m).
6. The chimney must extend at least three (3) feet (915 mm) above its point of contact with the roof and at least two (2) feet (610 mm) higher than any wall, roof or building within ten (10) feet (3m) of it (**Figure 17**).
7. If the chimney extends higher than five (5) feet (1,500 mm) above its point of contact with the roof, it must be secured using a roof brace.
8. A rain cap must be installed on top of the chimney. Failure to install a rain cap may cause corrosion problems.
9. Cut and frame square holes in all floors, ceilings, and roof that the chimney will go through to provide a 2" (50 mm) clearance between the chimney and any combustible materials. Do not fill this 2" space with insulation or any other combustible material.
10. Portions of the chimney which may extend through accessible spaces must be enclosed to avoid contact with combustible materials or damage to the chimney.
11. When offsets are used, the pipe may not penetrate a ceiling or floor unless it is running vertical (no 30° offsets).

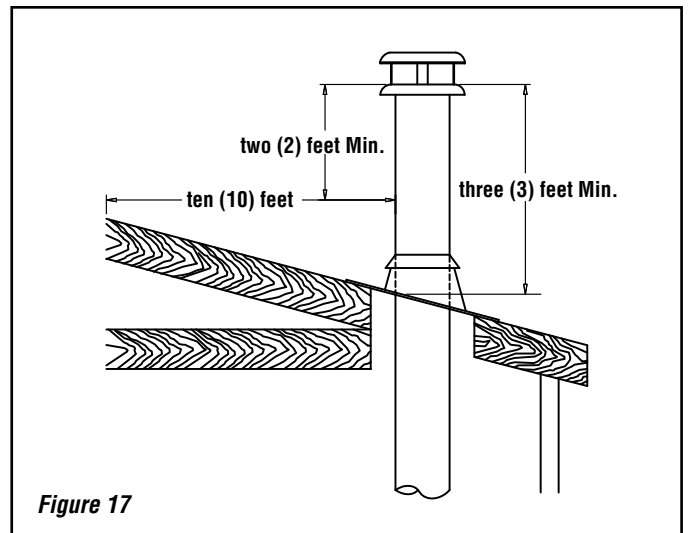

Note: 2" clearance to combustibles around chimney components required.

Note: Blown or fill type insulation materials must not be in contact with the fireplace or in the enclosure frame as described in "Enclosure" section.

Note: Local codes may not require firestopping at the ceiling levels for outside chase installations. However, it is recommended for safety and the reduction of heat loss.

CHIMNEY INSTALLATION INSTRUCTIONS

1. Cut and frame the holes in the ceiling, floor and roof where the chimney will pass (see **Figure 18**). Use a plumb-bob to line up the center of the holes. The sizes are indicated in **Table 2** for the floor and ceiling holes and **Table 3 (Page 12)** for the roof holes.

CHIMNEY MODEL	SQUARE HOLE SIZE OPENING
ASHT / HT6103+	12-3/8" (314 mm)
S-2100+ / HT6000+	14-1/8" (359 mm)
AC	15 in (380 mm)

Note: See Table 3 for Sloped Roof Framing
Table 2 - Flat Roof Framing

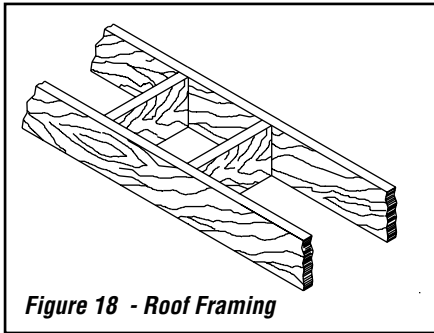

Figure 18 - Roof Framing

2. From below, install a firestop in each ceiling/floor separation through which the chimney will pass. At the attic level, install an attic radiation shield from above (**Figures 19a through 19d**).
3. For ASHT/HT6103+ AND S2100+ / HT6000+ chimneys place the first chimney length on the fireplace. To lock it in place, turn 1/4 of a turn clockwise. With the AC chimney, you must use a starter section (**AC6SB or AC6SB30**) before installing the first chimney length (**Figure 20**). Continue installing chimney lengths making sure to lock each length in place.
4. Every time the chimney passes through a ceiling or a wall, install the appropriate firestop. When you reach the desired height, install the roof support (Refer to instructions included with the support).
5. Then, put the roof flashing in place and seal the joint between the roof and the flashing with roofing pitch (see **Figures 21 and 22**). For sloping roofs, place the flashing under the upper shingles and on top of the lower shingles. Nail the flashing to the roof, using roofing nails.
6. Place the spacers and the storm collar over the flashing, and tighten it with the bolt supplied. Finally, seal the joint between the storm collar and the chimney, using silicone caulking.
7. Install the chimney cap. Once the chimney cap is in place, the roof flashing can be washed with a solvent or vinegar and then painted with rust-proof paint.

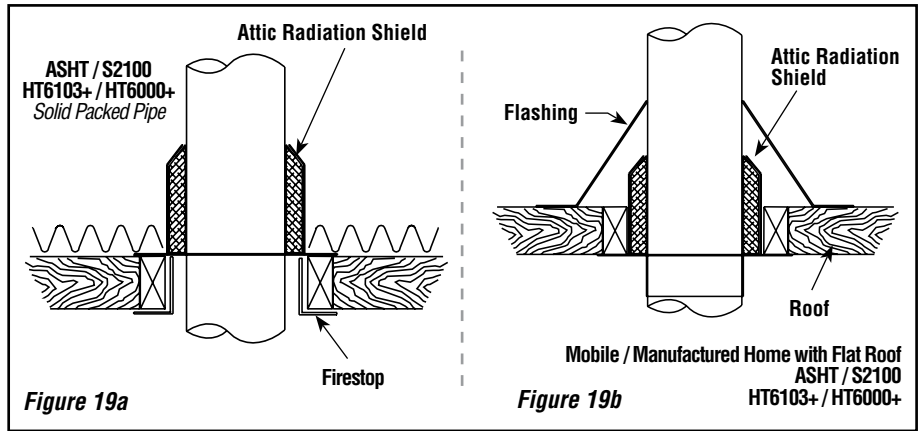

Figure 19a

Figure 19b

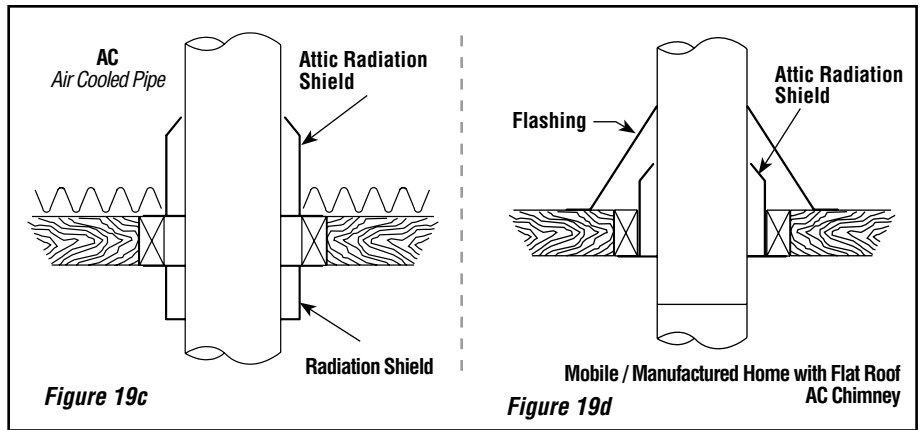

Figure 19c

Figure 19d

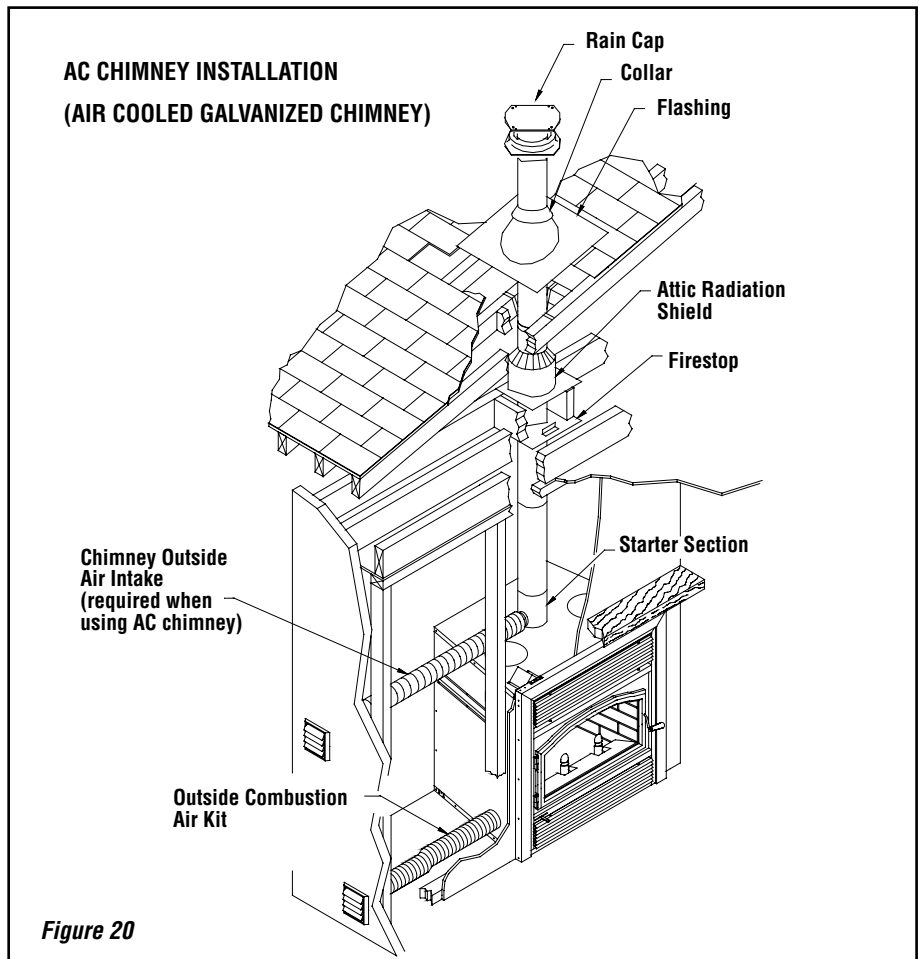
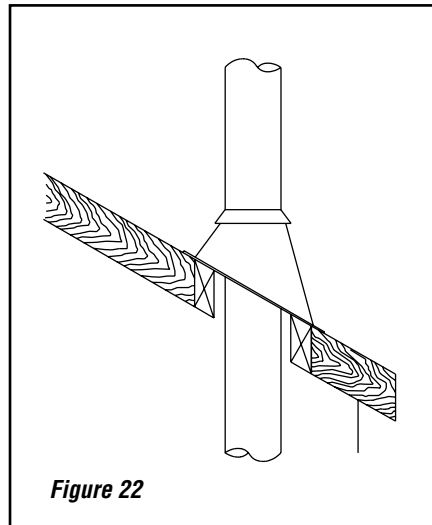
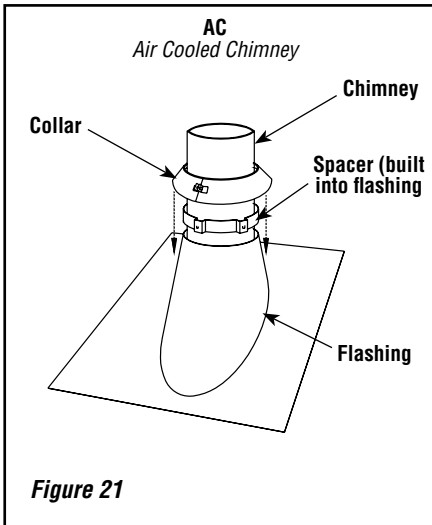

Figure 20



After reaching the location requiring the elbow, proceed as follows:

ASHT / HT6103+ / S-2100+ / HT6000+ Chimneys

1. Install the first elbow; turn it in the required direction. Fasten it to the chimney with the three (3) 1/2" (12 mm) metal screws provided with the elbow.
2. Install the necessary chimney lengths to achieve the required offset. Lock the chimney lengths together: it is recommended to use three (3) 1/2" (12 mm) screws. If the offset length is made of two (2) chimney lengths or more, use an offset or roof support halfway up the offset. If penetrating a wall, install a wall radiation shield (see **Figures 24 and 26**).
3. Use another elbow to turn the chimney vertically. Secure the elbow, using three (3) 1/2" (12 mm) screws (provided with the elbow).
4. Use a plumb-bob to line up the center of the hole. Cut a hole for the chimney in the ceiling/floor. Frame this hole as described previously (refer to section *Chimney Installation Instructions*).
5. From below, install a firestop (See **Figure 19a**).
6. A support (ST or SO+) must be used on the first 15' section (5 m).
7. Continue with the regular installation.

AC Chimney

1. Install the first elbow. Turn it in the required direction. To lock it in place, turn 1/8 of a turn. Fasten the straps attached to the elbow to the surrounding frame, using nails or drywall screws (**Figure 25**).
2. Install the necessary chimney lengths to achieve the required offset. Lock the chimney lengths together. If penetrating a wall, use a wall radiation shield.
3. Use another elbow to turn the chimney vertically. Lock it to the chimney. Fasten the straps attached to the elbow to the surrounding framing using nails or drywall screws.
4. Use a plumb-bob to line up the center of the hole. Cut a hole for the chimney in the ceiling. Frame this hole as described previously.
5. From below, install a firestop (see **Figure 19c**).
6. Continue with the regular installation.

Note: When using AC chimney, an AC6SB starter section must be used before installing an elbow. When an offset is needed immediately off the top of the fireplace, an elbow starter section, AC6SB30 (H3780), is available.

Roof Down Slope Hole Size			
SLOPE	ASHT / HT6103+	S-2100+ / HT6000+	AC
Roof Pitch	6"	6"	6"
0 *	12-3/8" (314 mm)	14-1/8" (359 mm)	15" (380 mm)
2/12	12-9/16" (319 mm)	14-3/8" (365 mm)	15 3/8" (390 mm)
4/12	13" (330 mm)	14-7/8" (378 mm)	16 1/8" (410 mm)
6/12	13-7/8" (352 mm)	15-3/4" (400 mm)	16 7/8" (430 mm)
8/12	14-7/8" (378 mm)	17" (432 mm)	18 1/4" (465 mm)
10/12	16-1/8" (410 mm)	18-3/8" (467 mm)	19 5/8" (500 mm)
12/12	17-1/2" (445 mm)	20" (508 mm)	21 3/8" (545 mm)

* Cross Slope Hole Size
Put the chimney cap into place.
Wash the roof flashing with a solvent or vinegar, then paint it with rust-proof paint.

Table 3

OFFSET CHIMNEY INSTALLATION

After reaching the location requiring the elbow, proceed as follows. The minimum chimney height when using elbows is:

Minimum Chimney Height Using Elbows	
Fireplace Model	Brentwood SP
Chimney Model	ASHT / S2100+ / HT6103+ / HT6000+ / AC
Vertical installation	12 feet (3.66 m)
Two (2) elbows	15 feet (4.57 m)
Four (4) elbows	17 feet (5.18 m)

Table 4

Notes:

- Must return to vertical before penetrating ceiling or floor.
- A maximum of 2 offsets are allowed.

Offset Dimensions

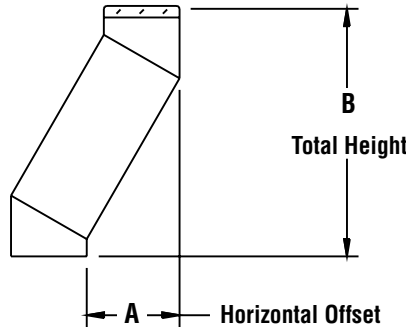

Chimney 6"	Elbow	Offset & Height	One Length Between Elbows						Two Lengths Between Elbows					
			8"	12"	18"	24"	36"	48"	8" & 48"	12" & 48"	18" & 48"	24" & 48"	36" & 48"	48" & 48"
Secure Temp ASHT Nova Temp HT6103+	15°	A	3-5/16" (84mm)	4-5/16" (110mm)	5-7/8" (149mm)	7-7/16" (189mm)	10-1/2" (267mm)	13-5/8" (346mm)	15-3/8" (391mm)	16-7/16" (418mm)	18" (457mm)	19-1/2" (495mm)	22-5/8" (575mm)	25-3/4" (654mm)
		B	15-11/16" (398mm)	19-9/16" (497mm)	25-3/8" (645mm)	31-3/16" (792mm)	42-3/4" (1086mm)	54-3/8" (1381mm)	60-15/16" (1548mm)	64-13/16" (1646mm)	70-9/16" (1792mm)	76-3/8" (1940mm)	87" (2210mm)	99-9/16" (2529mm)
	30°	A	7-7/16" (189mm)	9-7/16" (240mm)	12-7/16" (316mm)	15-7/16" (392mm)	21-7/16" (545mm)	27-7/16" (697mm)	30-13/16" (783mm)	32-13/16" (833mm)	35-13/16" (910mm)	38-13/16" (986mm)	44-13/16" (1138mm)	50-13/16" (1291mm)
		B	20" (508mm)	23-1/2" (597mm)	28-11/16" (729mm)	33-7/8" (860mm)	44-1/4" (1124mm)	54-11/16" (1389mm)	60-9/16" (1538mm)	64" (1627mm)	69-1/4" (1759mm)	74-7/16" (1891mm)	84-13/16" (2154mm)	95-1/4" (2419mm)
45°	A	10-5/16" (262mm)	13-3/16" (335mm)	17-3/8" (441mm)	21-5/8" (549mm)	30-1/8" (765mm)	38-5/8" (981mm)	43-7/16" (1133mm)	46-1/4" (1175mm)	50-1/2" (1283mm)	54-3/4" (1391mm)	63-1/4" (1607mm)	71-11/16" (1818mm)	
	B	17-13/16" (452mm)	20-5/8" (524mm)	24-7/8" (632mm)	29-1/8" (740mm)	37-5/8" (956mm)	46-1/8" (1172mm)	50-15/16" (1294mm)	53-3/4" (1365mm)	58" (1473mm)	62-1/4" (1581mm)	70-3/4" (1797mm)	79-3/16" (2011mm)	

Chimney 6"	Elbow	Offset & Height	One Length Between Elbows						Two Lengths Between Elbows					
			8"	12"	18"	24"	36"	48"	8" & 48"	12" & 48"	18" & 48"	24" & 48"	36" & 48"	48" & 48"
Secure Temp S2100+ Nova Temp HT6000	15°	A	3-5/16" (84mm)	4-5/16" (110mm)	5-7/8" (149mm)	7-7/16" (189mm)	10-1/2" (267mm)	13-5/8" (346mm)	15-1/2" (394mm)	16-1/2" (419mm)	18-1/16" (459mm)	19-5/8" (498mm)	22-3/4" (578mm)	25-13/16" (656mm)
		B	16" (406mm)	19-7/8" (505mm)	25-11/16" (652mm)	31-1/2" (800mm)	43-1/16" (1094mm)	54-5/8" (1387mm)	61-7/16" (1561mm)	65-1/4" (1657mm)	71-1/16" (1805mm)	76-7/8" (1953mm)	88-1/2" (2248mm)	100-1/16" (2542mm)
	30°	A	7-3/8" (187mm)	9-3/8" (238mm)	12-3/8" (314mm)	15-3/8" (391mm)	21-3/8" (543mm)	27-3/8" (695mm)	30-7/8" (784mm)	32-7/8" (835mm)	35-7/8" (911mm)	38-7/8" (987mm)	44-7/8" (1140mm)	50-7/8" (1292mm)
		B	20-11/16" (525mm)	24-3/16" (614mm)	29-3/8" (746mm)	34-9/16" (878mm)	44-15/16" (1141mm)	55-5/16" (1405mm)	61-3/8" (1559mm)	64-7/8" (1648mm)	70-1/16" (1780mm)	75-1/4" (1911mm)	85-5/8" (2175mm)	96" (2438mm)

Chimney 6"	Elbow	Offset & Height	One Length Between Elbows						Two Lengths Between Elbows					
			---	12"	18"	---	36"	48"	---	12" & 48"	18" & 48"	---	36" & 48"	48" & 48"
AC 6"	15°	A	---	4-13/16" (122 mm)	6-1/8" (156 mm)	---	11" (280 mm)	14-1/8" (359 mm)	---	16-7/8" (429 mm)	18-7/16" (468 mm)	---	23" (584 mm)	26-3/16" (665 mm)
		B	---	27-11/16" (703 mm)	33-1/2" (851 mm)	---	50-7/8" (1292 mm)	62-1/2" (1588 mm)	---	72-5/8" (1845 mm)	78-7/16" (1992 mm)	---	95-3/4" (2432 mm)	107-3/8" (2727 mm)
	30°	A	---	9-3/8" (238 mm)	12-3/8" (314 mm)	---	21-3/8" (543)	27-3/8" (695 mm)	---	32-5/8" (829 mm)	35-5/8" (905 mm)	---	44-5/8" (1134 mm)	50-5/8" (1286 mm)
		B	---	25-3/4" (654 mm)	31" (787 mm)	---	46-1/2" (1181 mm)	57" (1448 mm)	---	66" (1676 mm)	71-1/4" (1810 mm)	---	86-7/8" (2207 mm)	97-1/4" (2740 mm)

NOTE: With the AC chimney, a starting length of 6" high must be used on top of the fireplace before installing an elbow.

Figure 23

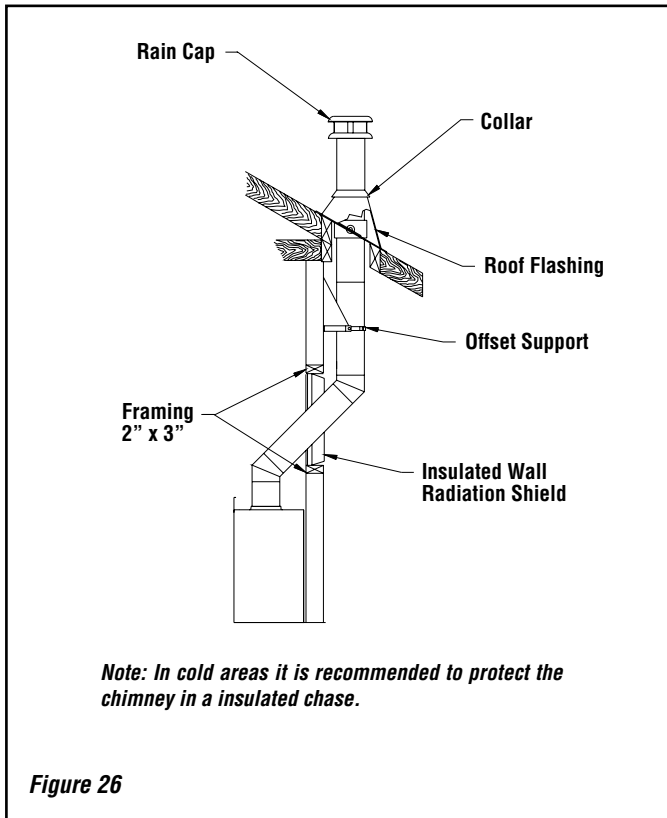
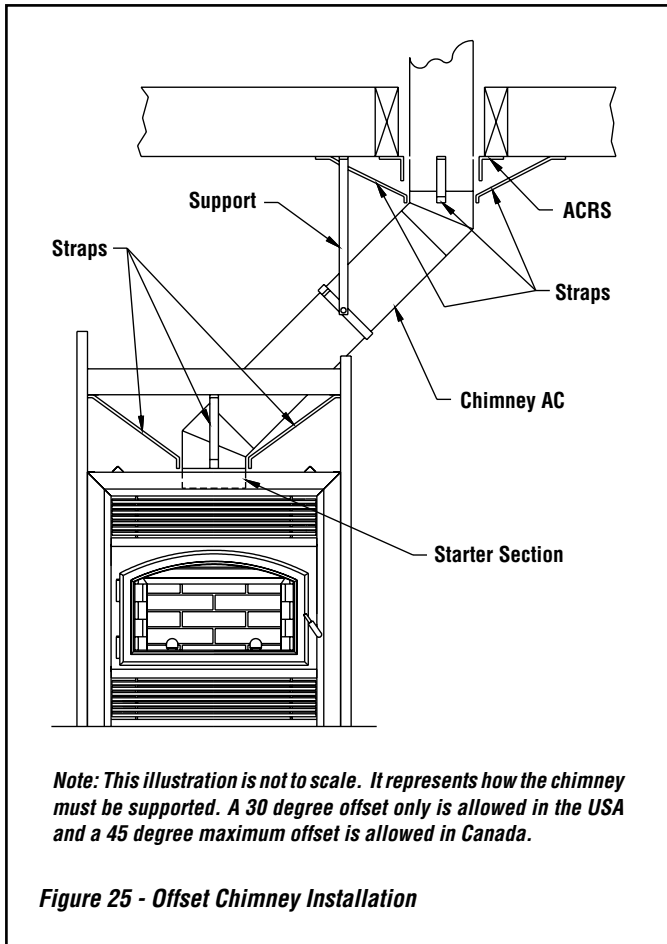

ANGLED WALL RADIATION SHIELD (RSM+ and RSMI30)

When traversing a combustible wall with the chimney at a 30° or 45° angle, an angled firestop or wall radiation shield must be installed. Only one is required.

Note: 45° angle for Canada only (RSMI45)

In cold climate locations (climates where temperatures will fall below 32° F / 0° C), we recommend that you use the insulated wall radiation shield since it will maintain the home's thermal barrier.

RSM+ and RSMI30 (RSMI45 - Canada Only)		
Chimney Model	Angle	Hole Size
ASHT / HT6103+ (6" dia). Canada only	30°	283 mm x 781 mm (11-1/8" x 30-3/4")
	45°	283 mm x 518 mm (11-1/8" x 20-3/8")
S-2100+ / HT6000+ / AC (6" dia).	30°	327 mm x 881 mm (12-7/8" x 34-11/16")
	30°	380 mm x 972 mm (15" x 38-1/4")

Table 5

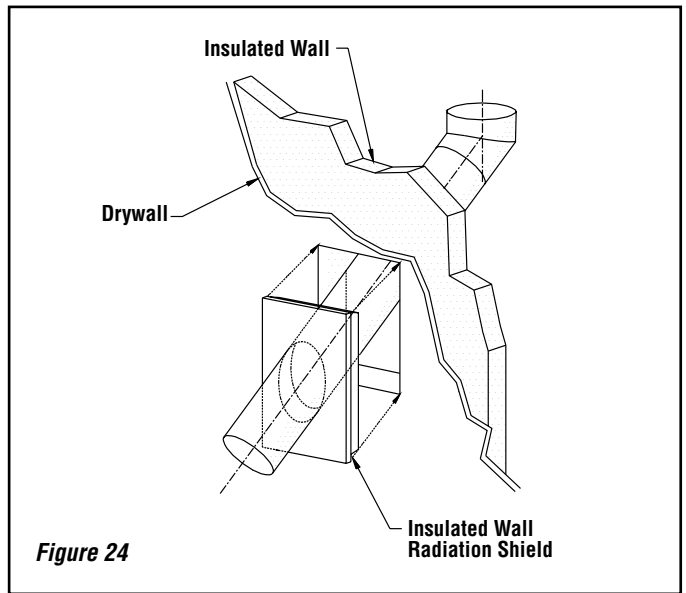

CHIMNEY SUPPORT INSTALLATION

Universal Roof Support

This support has three possible uses:

1. For ASHT / HT6103+ and S-2100+ / HT6000+, it must be used on a roof to support the chimney.
2. It may be used on a floor, ceiling or roof above an offset to support the chimney above the offset.
3. It may be used on a floor, ceiling or roof as a supplementary support.

Table 6 gives maximum height of supported chimney.

NOTE: For the AC chimney, a support section must be used every 40 feet (12 m) instead of the universal roof support (ST).

For roof support installation, refer to the instructions provided with the support.

Universal Offset Support

This support is used to support the chimney above an offset. When the chimney offset is used to traverse a wall this support may be used on the wall to support the chimney. The maximum heights are given in **Table 6**. For offset support installation, refer to the instructions provided with the support.

CHIMNEY MODEL	MAXIMUM HEIGHT OF SUPPORTED CHIMNEY	
	Offset Support	Roof Support
ASHT / HT6103+ (6" dia).	28 feet (8.54 m)	29 feet (8.84 m)
S-2100+ / HT6000+ (6" dia).	18 feet (5.49 m)	20 feet (6.1 m)
AC (6" dia).	40 feet (12.19 m)	50 feet (15.20 m)

Table 6

CHIMNEY CHASE AND MULTIPLE TERMINATIONS

For the purpose of this manual, a chimney chase is considered a part of the chimney system rather than part of a building. The termination must be placed a minimum of 18" (460 mm) above the chase.

For installations where more than one chimney is located in the same chase or within the same area, we suggest that their terminations be separated by at least 16" (410 mm) horizontally, and 18" (460 mm) vertically. This separation is to prevent smoke migrating from one chimney to another (see **Figure 27**).

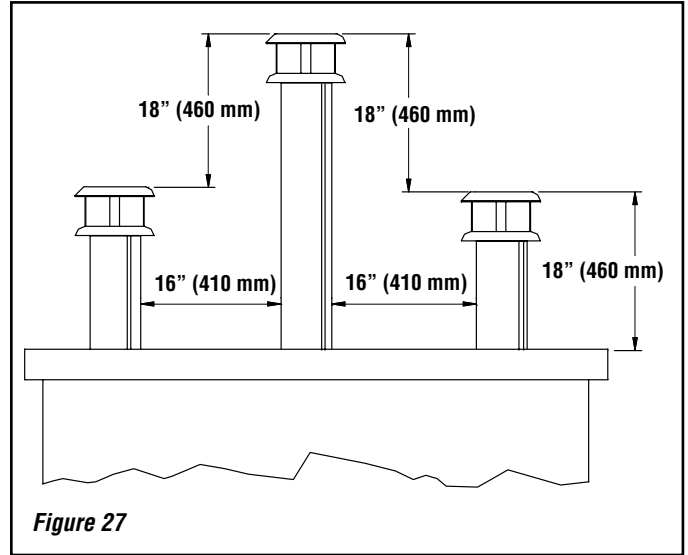

Figure 27

CHIMNEY ADAPTOR (S-2100+ / HT6000+) CANADA ONLY

The fireplace is normally supplied with a chimney adaptor suitable for the ASHT / HT6103+ chimney. If you want to install a S-2100+ / HT6000+ chimney, an adaptor is available (6UCA) (**Figure 28**). A separate starter section will also be required if AC chimney is installed.

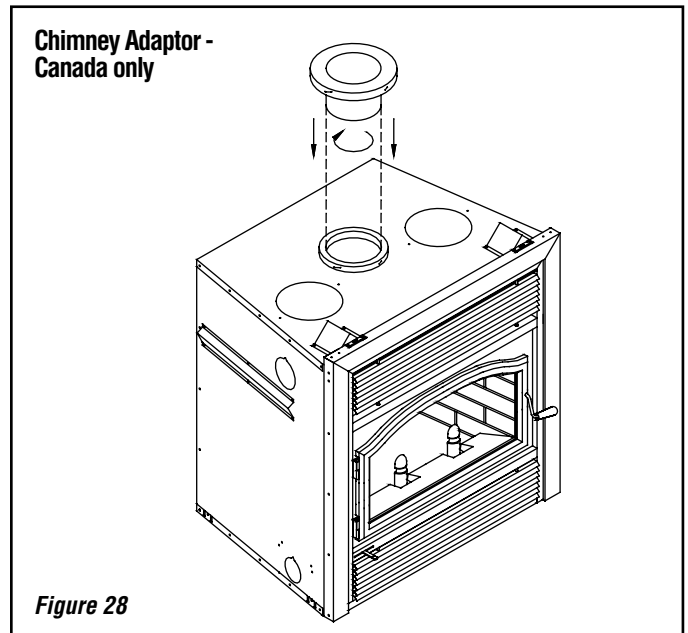

Figure 28

INSTALLATION INSTRUCTIONS FOR MASONRY APPLICATION

WARNING: Before starting the installation, the masonry chimney must be inspected by a qualified chimney sweep.

The following requirements must be respected:

1. The chimney must be absolutely clear of any soot residue or creosote. Check for cracks, loose or missing bricks that could inhibit correct installation of the liner.
2. The clearance to combustibles must be a minimum of 1" between the outside of the masonry and any wood framing or loose insulation.
3. The chimney must be built in accordance with the current building code.
4. No other appliance can be connected to the same chimney.
5. The clearances to combustibles for the BISUMA30 connectors are 2" on the side and bottom and 16" at the top.
6. The connector parts are not necessary if the connection between the insulated length and the stainless steel liner is done within the masonry chimney.

Installation:

The chimney must be relined with a stainless steel liner model TUBINOX or Projet SS of the same diameter as the outlet of the fireplace.

For connection at a 30° angle, a special connector (BISUMA30) must be used to connect the liner to the insulated chimney.

* **IMPORTANT NOTE - The use of a 45° connector (BISUMA) is approved for use in Canada ONLY. Installations in the USA must use the 30° connector (BISUMA30).**

Follow these steps:

- 1- Position the fireplace in its location. Temporarily install the ASHT elbow on the top of the fireplace and, using a level, mark with an oval the location where the flue liner will enter the masonry chimney.
- 2- In the middle of the oval, drill a hole in the masonry chimney at 30°.
- 3- Increase the size of the hole until a 30° TUBINOX liner elbow can be easily slipped through.
- 4- Slide the liner down from the top of the masonry chimney until you reach the hole level.
- 5- Slip through the hole a 30° liner elbow and connect it to the liner.
- 6- Add a small liner section to the liner elbow which will allow the liner to extend at least 12" (measured at the top of the liner) from the masonry chimney.
- 7- Seal the opening around the liner with high temperature refractory cement.
- 8- The next steps must be done in the following order:

See typical installation illustrated below.

- A. Select the ASHT length that will fit between the elbow and the liner so that it will slide at least 2" over the liner section (You may need to cut the liner for a better fit).
- B. Take that section and the BISUMA30 cover and slide it over the liner. Make sure you have enough opening to be able to install the ASHT elbow without difficulty.
- C. Install the 30° elbow on the fireplace.
- D. Slide the length section back down on the elbow and twist lock the two together.
- E. Pull the cover down over the length and install the insulation pad over the liner; be careful to cover the liner completely.
- F. Slide back the cover over the insulation and fix it in place using the 3 metal screws supplied.

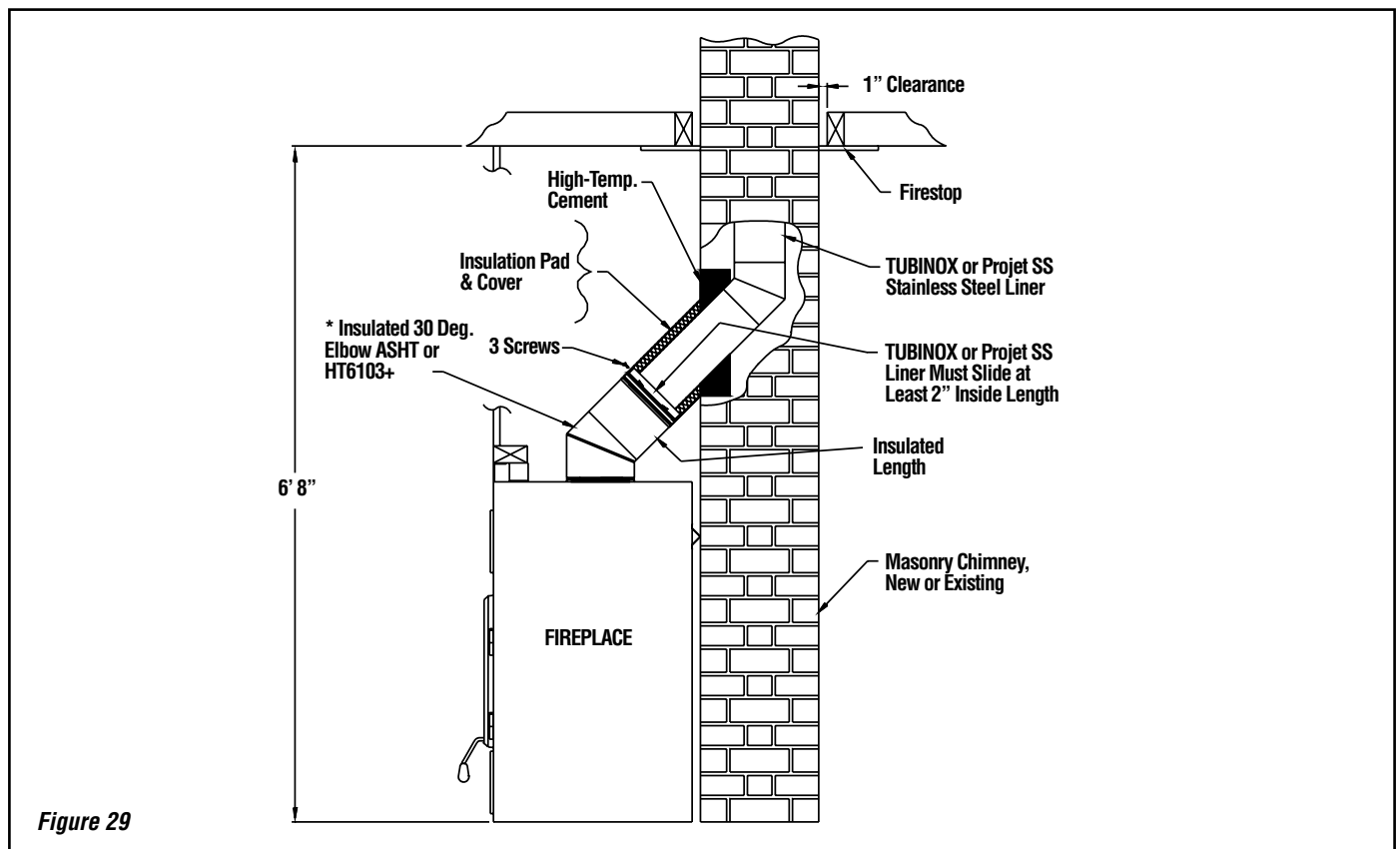

Figure 29

OPTIONAL INSTALLATION ACCESSORIES

Installation Accessories	
Description	Cat./Part No.
(Required - Order Separately)	
Black Cast Iron Door for Brentwood™, BWBK	H0516
Gold Plated Cast Iron Door for Brentwood, BWG	H0517
Brushed Nickel Cast Door for Brentwood, BWBN	H4849
Outside Air Kit (Required - Included With Fireplace)	
Outside Air Coupler to connect outside air UZI to fireplace, UZIAD	UZIAD
Outside Air Ducting - includes 4" insulated flex x 10' long, UZI	UZI
Gravity Kits	
Gravity Kit - Complete double ducting system w/adaptor including: 2 elbows 90°, 2 telescopic lengths, 2 grill supports and 2 black grills, 7B30ZK-1	7B30ZK-1
Gravity Kit Accessories	
Black grill with support, Part# 7B30ZO	7B30ZO
Brass grill (for 7B30ZK), 7B30ZGB	7B30ZGB
Elbow 90°, 8" dia., 7B26ZE90	7B26ZE90
Elbow 45°, 8" dia., 7B26ZE45	7B26ZE45
Telescopic length, 8" dia., 7B26ZLA	7B26ZLA
Adjustable length 8" dia (2" - 5"), 7B26ZL2A	7B26ZL2A
Wall Radiation shield, 7B26ZR	7B26ZR
Length five (5) feet, 8KL5	8KL5
Length four (4) feet, 8KL4	8KL4
Length three (3) feet, 8KL3	8KL3
Length two (2) feet, 8KL2	8KL2
Length one (1) feet, 8KL1	8KL1

Fireplace Kits	
Description	Cat./Part No.
Blower (heat activated on/off pre-wired), UZY5	UZY5
Blower motor speed control (wall mount), VRUW	VRUW
Rigid firescreen	BUCEBWZN
Masonry Chimney Adaptor, 30°, BISUMA30 (for use with TUBINOX liner)	BISUMA30
Central Forced Air Kit Accessories ❶	
Central Forced Air Kit, Central forced air kit including: blower (BISZY), flex adaptor (BISAF), 2 clamps, variable speed control (VRUW), thermo-disk (VTU), fan to flexible pipe adapter (BISAVF), back draft damper (BISBD), aluminium tape, BISFWK-1	BISFWK-1
Fireplace to Flex adaptor and 2 clamps, BISAF	BISAF
Flexible pipe 5" I.D. x 15 ft. Long, 5FLEX15	5FLEX15
Flexible pipe 5" I.D. x 30 ft. Long, 5FLEX25	5FLEX25
Blower 250 CFM for central forced air kit, BISZY	BISZY
Blower variable speed control with decorative wall plate for (BISZY), VRUW	VRUW
Thermo-disk, on/off blower control (for BISZY), VTU	VTU
Blower to flexible pipe adaptor, BISAVF	BISAVF
Heating and cooling thermostat, 24V, HCTW	HCTW
Backdraft damper, BISBD	BISBD

❶ **Not tested under EPA certification. If installed, this appliance no longer qualifies for EPA certification.**

*** For installation, follow the instructions included with the Central Forced Air Kit.**

CHIMNEY - PARTS AND COMPONENTS LISTS

Secure Temp ASHT 1" High Temp. Insulated Stainless Steel Chimney <i>6" I.D and 8" O.D., Double-Wall Stainl. Steel, Listed to CAN/UCL-S604 and UL-103HT</i>	
Description	Part/Cat. No.
Lengths and Misc. Chimney Components	
8" length, 6" Dia., 6L8	6L8
12" length, 6" Dia., 6L12	6L12
18" length, 6" Dia., 6L18	6L18
24" length, 6" Dia., 6L24	6L24
36" length, 6" Dia., 6L36	6L36
48" length, 6" Dia., 6L48	6L48
Adjustable Length 12", 6" Dia., 6LA	6LA
15° elbow, 6" Dia., 6E15	6E15
30° elbow, 6" Dia., 6E30	6E30
Rain Termination Cap, 6" Dia., 6CC	6CC
Spark Arrester Screen (universal spark arrester band), PE	PE
Wall Band, BM	BM
Supports	
Offset Support, SO	SO
Roof Support, ST	ST
Roof Brace, BS2	BS2
Firestops	
Firestop, 6BF	6BF
Radiation Shield, 6RS	6RS
Insulated Attic Radiation Shield, 6RSA	6RSA2
Insulated Wall Radiation Shield, 6RSM	6RSM
Insulated Wall Radiation Shield, 30°, 6RSMI30	6RSMI30
Uninsulated Wall Radiation Shield, 30°, 6RSM30	6RSM30
Attic Radiation Shield	H0487
Roof Flashings	
Flat Roof Flashing, 6FR	6FR
1/12 - 7/12 (5° - 30°), 6FAR	6FAR
8/12 - 12/12 (30° - 45°), 6FBR	6FBR
Storm Collar, 6FC	6FC

Fireplace Model Brentwood SP - Approved Venting Components manufactured by Security Chimneys International only.

- **6" diameter chimney** - AC (air cooled), Secure Temp™ ASHT (or Nova Temp™ HT6103+) and Secure Temp S-2100+ (or Nova Temp HT6000+).
- **6" diameter chimney for relining masonry chimneys** - TUBINOX chimney (or PROJET SS), 6" diameter with adaptor for installation in a masonry chimney.

Notes:

- ① *Nova Temp HT6000+ is equivalent to Secure Temp S-2100+*
- ② *Nova Temp HT6103+ is equivalent to Secure Temp ASHT*
- ③ *This appliance is equipped with the ASHT Chimney Adaptor. When other chimney is used, a chimney adaptor for that chimney will be required.*
- ④ *Chimney Adaptor (S-2100+ / HT6000+) for CANADA ONLY - If you want to install a S-2100+ / HT6000+ chimney, an adaptor is available (6UCA).*
- ⑤ *AC Chimney is NOT recommended at elevations above 4,000 feet or in cold climates (climates where temperatures will fall below 32° F / 0° C). When using AC chimney, an AC6SB starter section must be used before installing an elbow. When an offset is needed immediately off the top of the fireplace, an elbow starter section, AC6SB30 (H3780), is available.*

CHIMNEY - PARTS AND COMPONENTS LISTS

(AC) Air-Cooled Chimney System*	
6" I.D. and 11" O.D. Air Cooled, Stainl. Steel inner and zinc coated steel exterior	
AC Starter Adaptors One of the following adaptors is required if installing an AC chimney system	
<i>* AC Chimney is NOT recommended at elevations above 4,000 feet or in cold climates (climates where temperatures will fall below 32° F / 0° C).</i>	
Description	Cat./Part No.
Starter Section (adaptor), 6", AC, AC6SB	H3779
Starter 30° Elbow, 6" AC, AC6SB30	H3780
The following outside air kit is required if installing an AC chimney system	
Chimney Outside Air Kit (flex, insulation, outside register and coupling), ACZI	H1967
Lengths and Misc. Chimney Components	
12" Length, 6" Dia. x 12" Long, AC6L12	H0472
18" Length, 6" Dia. x 12" Long, AC6L18	H0473
36" Length, 6" Dia. x 36" Long, AC6L36	H0474
48" Length, 6" Dia. x 48" Long, AC6L48	H0475
15° Elbow, 6" Dia., AC6E15	H0476
30° Elbow, 6" Dia., AC6E30	H0477
Rain Termination Cap, 6" Dia., AC6CPR	H0478
Spark Arrester Screen (universal spark arrester band), PE	PE
Wall Band, XBM	XBM
Supports	
Offset Support, SO	SO
Support Section, AC6SL	H0481
Roof Support, ST	ST
Roof Brace, BS2	BS2
Roof Flashings	
Flat Roof Flashing, ACF	H0494
1/12 - 7/12 (5° - 30°), AC Adj. Roof Flashing, FA	H0495
8/12 - 12/12 (30° - 45°), AC Adj. Roof Flashing, FB	H0496
Storm collar, ACFC	H0500
Misc.	
Telescopic attic radiation shield, ACRST	H0498
Firestop, ACBF	H0485
Radiation Shield, ACRS	H0486
Attic Radiation Shield, ACRSA	H0487
Insulated Wall Radiation Shield, 30°, ACRSMI30	H0489

TUBINOX LL Chimney Lining System	
Rigid Stainless Steel Liner For Relining A Masonry Chimney, 6" Diameter <i>Listed to ULC-S635M, UL-1777 and ULC-S640M at 2100° F</i>	
Description	Cat./Part No.
6" Length, 6" Dia., 6LL6	6LL6
12" Length, 6" Dia., 6LL12	6LL12
24" Length, 6" Dia., 6LL24	6LL24
36" Length, 6" Dia., 6LL36	6LL36
48" Length, 6" Dia., 6LL48	6LL48
Adjustable Length (7" to 11"), 6" Dia., 6L7A	6L7A
Split Base Tee, 6" Dia., 6LT	6LT
Tee Cap, 6" Dia., 6TCS	6TCS
Twist Lock Tee Cap, 6" Dia., 6LTC	6LTC
Elbow 30°, 6" Dia., 6LE30	6LE30
Elbow 45°, 6" Dia., 6LE45	6LE45
Elbow 90°, 6" Dia., 6LE90	6LE90
Rain Termination Cap (regular), 6" Dia., 6LCS	6LCS
Rain Termination Cap (deluxe), 6" Dia., 6LCC	6LCC
Spark Arrester Screen (universal spark arrester band), PE	PE
Supports	
Top Support, 6LST	6LST
Support Assembly, 6LSA	6LSA
Interior Support, 6LSB	6LSB
Adaptor Flexible Pipe (male), 6LAAM	6LAAM
Adaptor Flexible Pipe (female), 6LAAF	6LAAF
Stainless Steel Flex - five (5) feet Long, 6LLFLEX	6LLFLEX
Adjustable Insulated Wall Radiation Shield 6" - 12", 6LRSMI	6LRSMI
Adaptors to Masonry Chimney	
Masonry Chimney Adaptor, 45°, BISUMA (for use with TUBINOX liner) CANADA ONLY	BISUMA
Masonry Chimney Adaptor, 30°, BISUMA30 (for use with TUBINOX liner)	BISUMA30

REPLACEMENT PARTS LIST

Brentwood™ Replacement Parts	
Description	Cat./Part No.
Baffle refractory (2 pieces)	PR-IS02205
Back refractory	PR-SR2203
Right side refractory	PR-SR2204D
Left side refractory	PR-SR2204G
Bottom refractory	PR-SR2201
Front refractory, right side - ash lip	PR-SR2202D
Front refractory, left side - ash lip	PR-SR2202G
Door handle	PR-SR2325
Ceramic glass panel	PR-SR2222-1
Secondary air tube	PR-SR2271
Cast-iron log retainer supports - grate (2)	PR-SR2324
Cast iron log retainer bar (w/Lennox logo)	PR-SR2323
Touch-up paint, aerosol, black metallic SBMB6309	70K99
Louvers, upper and lower (1)	PR-SR2218-1
Snap disc, blower	VTU
Bracket, secondary air tube	PR-SR2214
Hinge assembly, fireplace and door	PR-SR2395UL
Door handle rod and mechanism	PR-SR2118
Door handle and brass cap	PR-SR2325
Door handle brass cap	POIGNE002
Gasket, door, 73" (5/8" dia.)	PR-SR1823G
Gasket, glass, 69" (5/16" dia.)	PR-SR1823H

Contact an Authorized Lennox Hearth Products dealer to obtain any of these parts. Never use substitute materials not approved by Lennox Hearth Products. Use of non-approved parts can result in poor performance and safety hazards.

SPECIFICATIONS

Cat. No.	Model
H4825	Brentwood SP

Product Reference Information	
Weight	385 lbs
Height	36"
Width	36"
Depth	24-1/2"
Firebox W x H x D - measured in front	22" x 11-3/4" x 12"
Chimney weight ASHT (6" dia)	6.25 lb/ft.
Chimney weight AC (6" dia)	3.25 lb/ft.

CLEARANCE TO COMBUSTIBLES

The following clearances meet the minimum requirements for a safe installation:

Side wall: 17" (324 mm) measured from the fireplace side.

Ceiling: 6' 8" (2,032 mm) measured from the base of the fireplace.

Fireplace enclosure:

Bottom: 0"

Side: 0" to spacer

Back: 0" to spacer

Top: Do not fill the space above the fireplace with any material (Except the wood framing. See **Page 9, Figure 8**).

Chimney: 2" (50 mm)

Mantel: 45" (1143 mm) measured from the base of the fireplace.

WARRANTY

Your fireplace is covered by a limited warranty. Please read the warranty to be familiar with its coverage.

Retain this manual. File it with your other documents for future reference.

PRODUCT REFERENCE INFORMATION

We recommend that you record the following important information about your fireplace. Please contact your Lennox Hearth Products dealer for any questions or concerns. For the number of your nearest Lennox Hearth Products dealer, please call 1-800-9-LENNOX.

REPLACEMENT PARTS

See **Page 23** for a complete replacement parts list. Use only parts supplied from the manufacturer.

Normally, all parts should be ordered through your Lennox Hearth Products distributor or dealer. Parts will be shipped at prevailing prices at time of order.

When ordering repair parts, always give the following information:

1. The model number of the appliance.
2. The serial number of the appliance.
3. The part number.
4. The description of the part.
5. The quantity required.
6. The installation date of the appliance.

If you encounter any problems or have any questions concerning the installation or application of this system, please contact your dealer.

LENNOX HEARTH PRODUCTS
1508 Elm Hill Pike, Suite 108
Nashville, TN 37210
Visit us at www.Lennox.com

Your Fireplace's Model Number _____
Your Fireplace's Serial Number _____
The Date On Which Your Fireplace Was Installed _____
Your Dealer's Name _____
Your Dealer's Phone Number _____

NATIONAL FIREPLACE INSTITUTE

CERTIFIED
www.nficertified.org

We recommend that our woodburning hearth products be installed and serviced by professionals who are certified in the U.S. by the National Fireplace Institute® (NFI) as NFI Woodburning Specialists or who are certified in Canada by Wood Energy Technical Training (WETT).

 **Wood Energy Technical Training**
www.wettinc.ca

NATIONAL FIREPLACE INSTITUTE

CERTIFIED
www.nficertified.org

Nous recommandons que nos p eles   bois soient install es et que l'entretien soit effectu e par des professionnels certifi es, aux Etats-Unis par le National Fireplace Institute® (NFI) et au Canada, par le Wood Energy Technical Training (WETT).

 **Wood Energy Technical Training**
www.wettinc.ca

Lennox Hearth Products reserves the right to make changes at any time, without notice, in design, materials, specifications, prices and also to discontinue colors, styles and products. Consult your local distributor for fireplace code information.

LENNOX
HEARTH PRODUCTS