



HEARTH PRODUCTS

HEARTH PRODUCTS
KITS AND ACCESSORIES

775232M
REV. A 09/2010

Cat. No.
71161
71162

Description
6" Positive Flue Connector Ring Kit
8" Positive Flue Connector Ring Kit

INSTALLATION INSTRUCTIONS FOR POSITIVE FLUE CONNECTOR KITS FOR USE WITH MODELS C160, CA160, C210, CA210, C260, E260, C310 WOOD FIREPLACE INSERTS



KIT CONTENTS:

(See *Figures 1 and 2*)

- 1 ea. 6" Positive Flue Connector Ring or 8" Positive Flue Connector Ring
- 1 ea. 6" Positive Flue Connector Ring Gasket or 8" Positive Flue Connector Ring Gasket
- 4 ea. 10-24 x 1/2" Self-Tapping Allen Head Screws
- 4 ea. Sheet-Metal Screws
- 4 ea. Washers
- 1 ea. Instruction Sheet

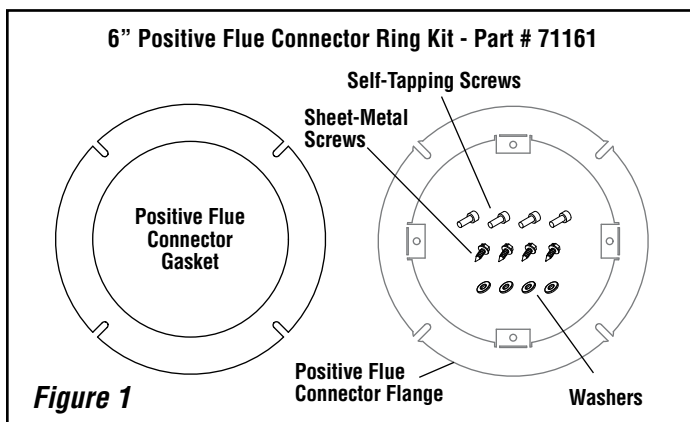

Figure 1

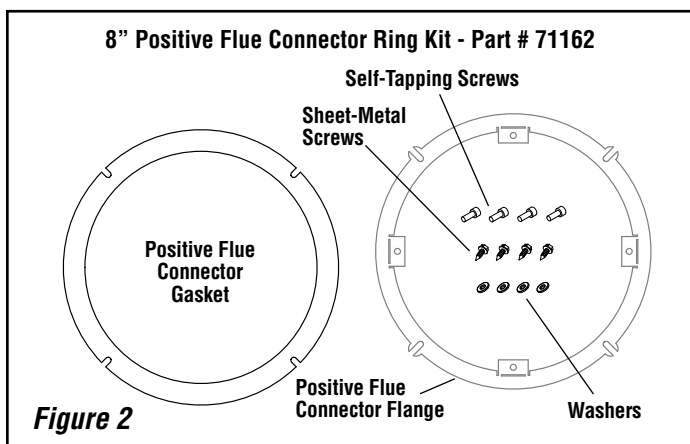

Figure 2

TOOLS / SUPPLIES NEEDED:

(See *Figure 3*)

- 1/4" Socket & Ratchet or Nut Driver .
- 5/32" T-Handle or Allen Wrench
- Pliers



Figure 3 - Tools Needed

GENERAL INFORMATION

These kits are designed to be used with the fireplace inserts indicated above to achieve a positive flue connection in fireplace installations. If you encounter any problems, need clarification of these instructions or are not qualified to properly install this kit, contact your local distributor or dealer.

INSTALLATION INSTRUCTIONS

Step 1. Using pliers bend the tabs on the positive flue connector ring so that they are perpendicular as shown in *Figure 4*.

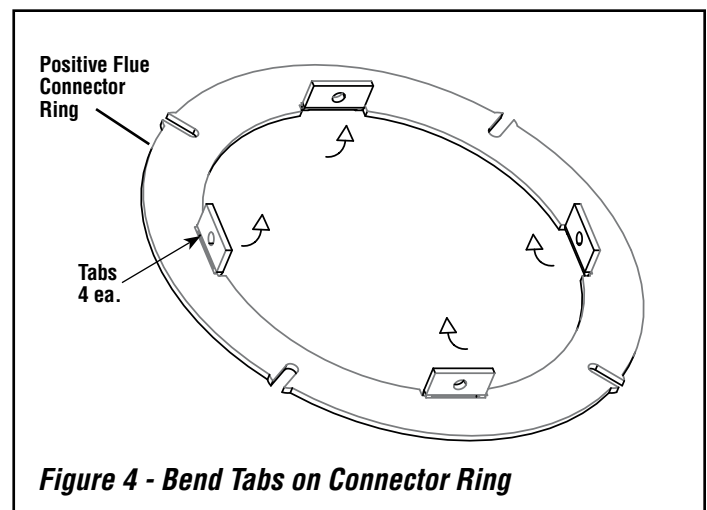
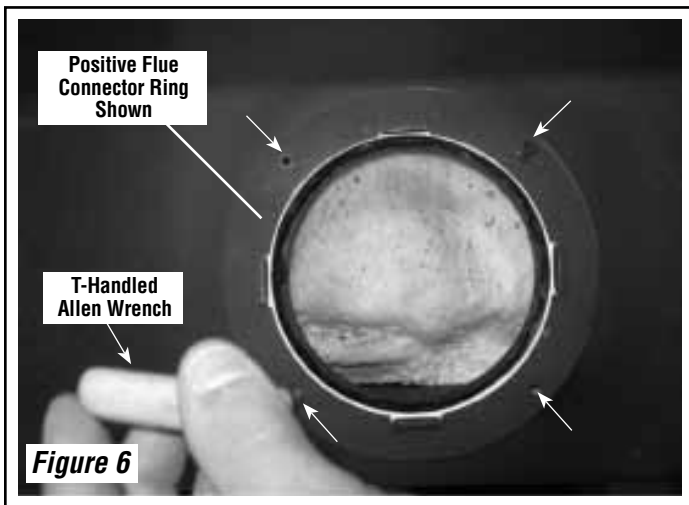
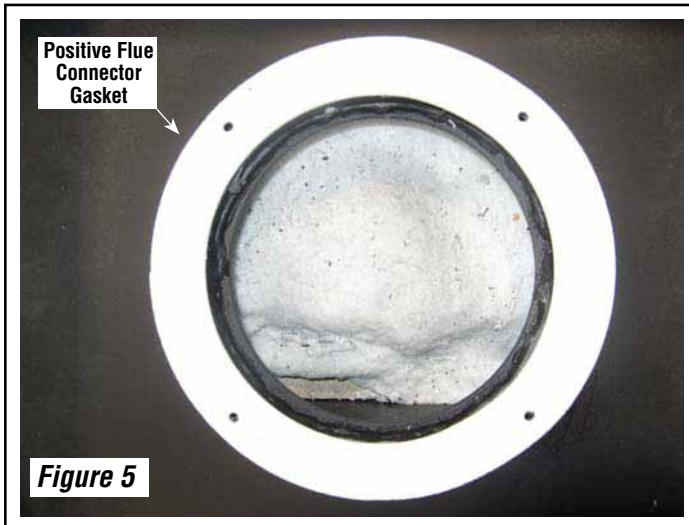

Figure 4 - Bend Tabs on Connector Ring

Step 2. Set gasket on the top of the insert lined up with the existing holes as shown in **Figure 5**. Place the Connector Ring on the flue opening as shown in **Figure 6**. Secure the flange in place using the four 10–24 x 1/2" self-tapping allen head screws (indicated by white arrows in **Figure 6**).



Step 3. Use of a stainless steel flex liner will require a flex pipe adaptor like the one shown in **Figure 7** (available from Security Chimneys™). Slide the adaptor over the flex and attach with sheet metal screws as shown in **Figure 7**. Slide the adaptor into the flange and flue opening as shown in **Figure 8**. Use the four sheet metal screws supplied in the kit to secure the flex adaptor to the flange.

Step 4. When using rigid pipe, simply slide the rigid pipe down into the adaptor. Using the four sheet metal screws supplied, fasten the pipe to the adaptor as shown in **Figure 8**.

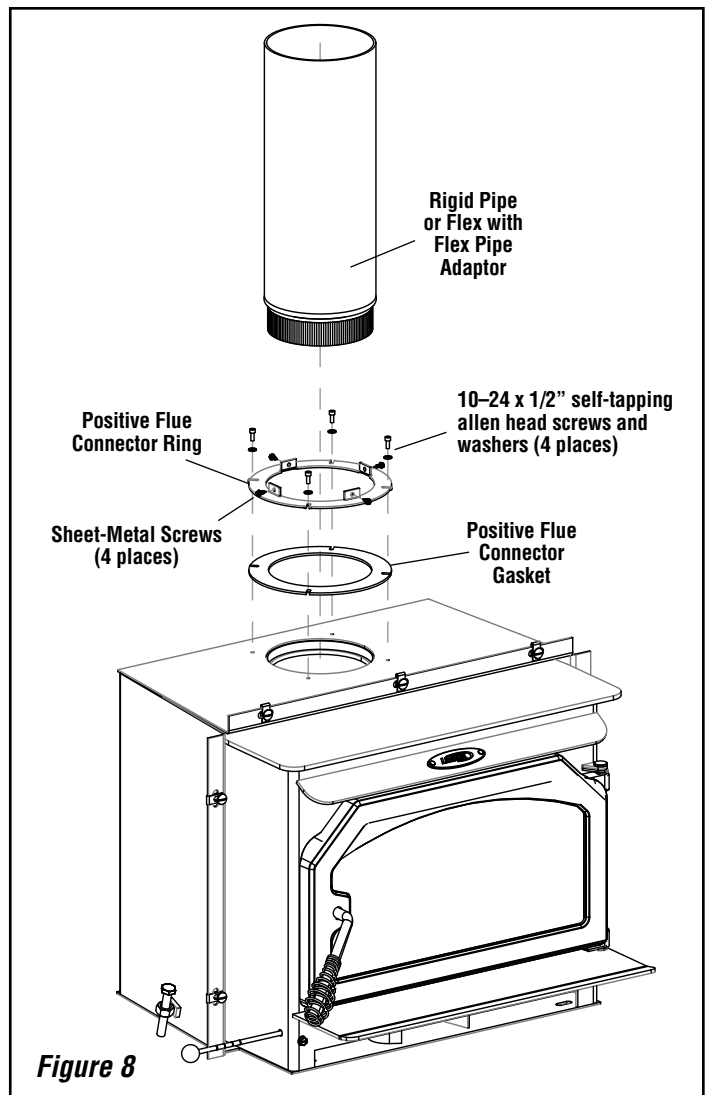
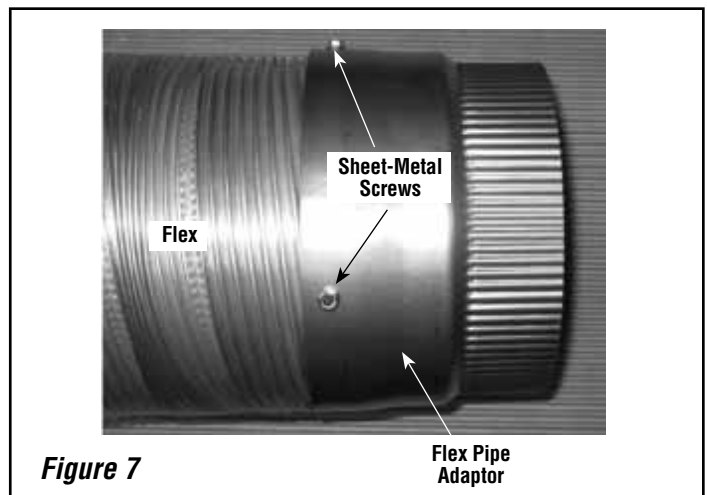

NOTE: DIAGRAMS & ILLUSTRATIONS ARE NOT TO SCALE.

Lennox Hearth Products reserves the right to make changes at any time, without notice, in design, materials, specifications, prices and also to discontinue colors, styles and products. Consult your local distributor for fireplace code information.